

**DUO-FAST**  
CONSTRUCTION

Round Head Nailer

**CN-350B**

0073163

DUO-FAST

AN ITW COMPANY

955 National Parkway

Schaumburg, Illinois 60173-5172

U.S.A.

© 2007 DUO-FAST CONSTRUCTION 1012458-24

07/07

TORQUE  
IN - LBS  
.45 IN - LBS

\* PART OF CN-120  
\*\* PART OF CN-230-P2  
\*\*\* PART OF CN-410-P1  
^ PART OF CN-434-P1  
> PART OF XK-1173

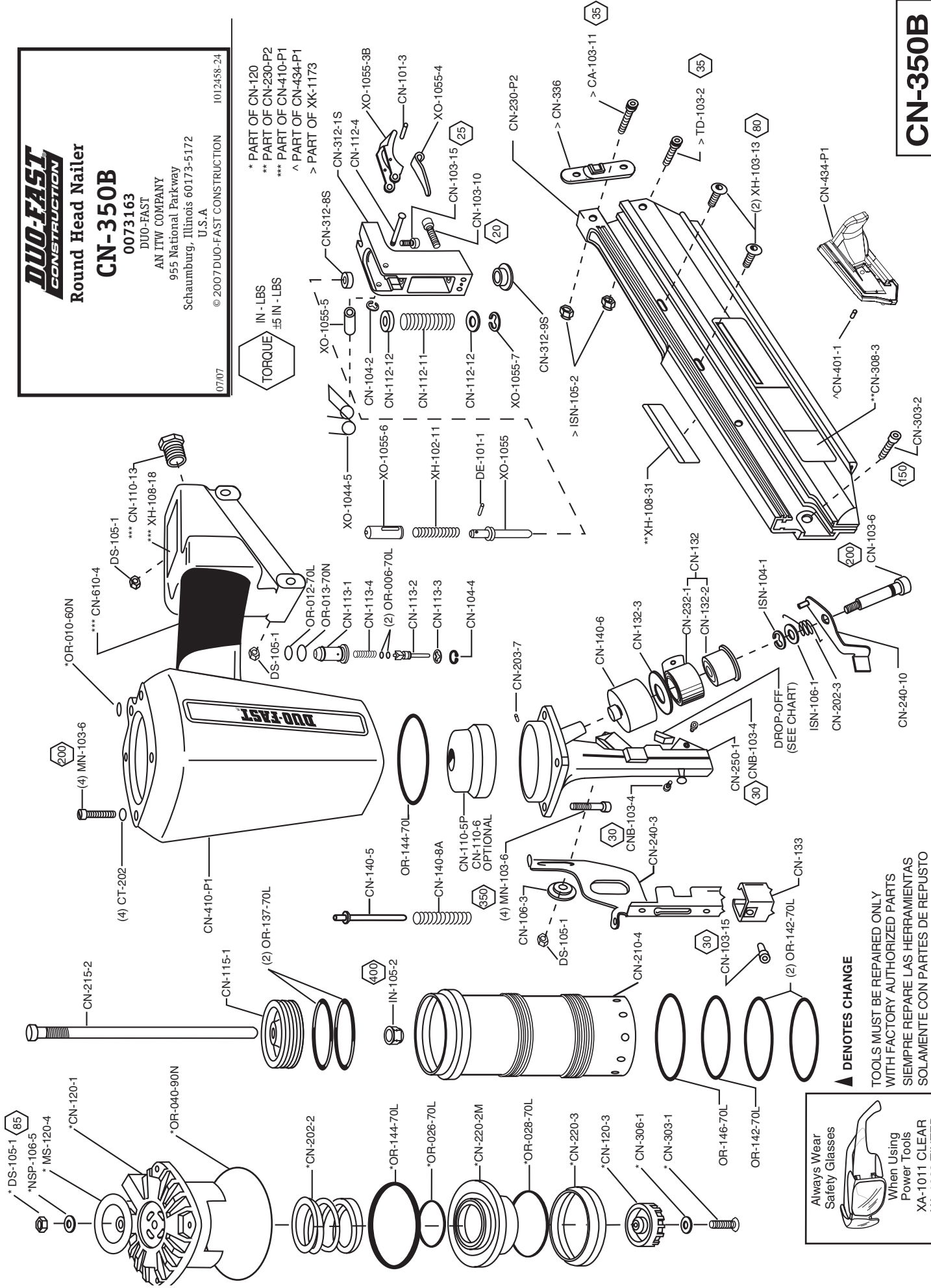

▲ DENOTES CHANGE

TOOLS MUST BE REPAIRED ONLY  
WITH FACTORY AUTHORIZED PARTS  
SIEMPRE REPARA LAS HERRAMIENTAS  
SOLAMENTE CON PARTES DE REPUESTO  
AUTORIZADAS POR DUO-FAST

Always Wear  
Safety Glasses



When Using  
Power Tools  
XA-1011 CLEAR  
XA-1022 TINTED

**CN-350B**

UNIQUE #	PART NO.	DESCRIPTION	REPLACES	UNIQUE #	PART NO.	DESCRIPTION	REPLACES
0397943	CA-103-11	SCREW		0062794	CN-312-1S	TRIGGER HOUSING	
0435438	CN-101-3	ROLL PIN		0062802	CN-312-8S	UPPER BUSHING	
0435784	CN-103-6	SCREW		0062810	CN-312-9S	LOWER BUSHING	
0435800	CN-103-10	SCREW		1015385	CN-336	PUSHER STOP ASSEMBLY	
0429902	CN-103-15	SCREW		1013064	CN-401-1	ROLL PIN	
0435495	CN-104-2	RETAINING RING		1011872	CN-410-P1	HANDLE - PART. ASM.	
0435503	CN-104-4	RETAINING RING		1012593	CN-434-P1	PUSHER ASSEMBLY	
0435586	CN-106-3	BUSHING		0074583	CN-610-4	CUSHION GRIP	
0443283	CN-110-5P	BUMPER		0446526	CNB-103-4	SCREW	
0441394	CN-110-6	BUMPER - OPT.		0437871	CT-202	WASHER	
0414813	CN-110-13	HEX BUSHING		0403246	DE-101-1	ROLL PIN	
0435602	CN-112-4	TRIGGER PIN		0173955	DS-105-1	NUT	
0435644	CN-112-11	SPRING SAFETY - OUTER		0412676	IN-105-2	NUT	
0407270	CN-112-12	SPRING RETAINER		0413401	IN-142-3	DRIVE SCREW	
0435271	CN-113-1	VALVE CARTRIDGE		0413856	ISN-101-2	ROLL PIN	
0435289	CN-113-2	TRIGGER VALVE		0413906	ISN-104-1	E-RING	
0435859	CN-113-3	VALVE RETAINER		0413930	ISN-106-1	WASHER	
0435651	CN-113-4	SPRING		0017335	MIN-103-6	SCREW	
0435297	CN-115-1	PISTON		0420307	MS-120-4	EXHAUST DEFLECTOR	
0406371	CN-120	CAP ASSEMBLY		0196345	OR-006-70L	O-RING	
0435875	CN-120-1	CAP (MACHINED)		0414409	OR-010-60N	O-RING	
0435511	CN-120-3	EXHAUST SEAL		0197913	OR-012-70L	O-RING	
0436444	CN-132	NEGATOR SPRING ASM.		0391615	OR-013-70N	O-RING	
0435891	CN-132-2	SPRING DRUM		0198028	OR-028-70L	O-RING	
0435909	CN-132-3	WASHER		0412445	OR-040-90N	O-RING	
0490169	CN-133	YOKE EXTENSION ASM.		0201806	OR-026-70L	O-RING	
0435347	CN-140-5	YOKE SPRING GUIDE		0202374	OR-137-70L	O-RING	
0435941	CN-140-6	SPRING SHIELD		0192799	OR-142-70L	O-RING	
0046334	CN-140-8A	SPRING (WORK CONTACT ELE.)		0211664	OR-144-70L	O-RING	
0123984	CN-202-2	SPRING, POPPET		0202408	OR-146-70L	O-RING	
0155093	CN-202-3	TORSION SPRING		0428888	TD-103-2	SCREW	
0414508	CN-203-7	OVAL POINT SET SCREW		0456772	XA-1011	EYE PROTECTION-CLEAR	
0437236	CN-210-4	CYLINDER SLEEVE		0277806	XA-1022	EYE PROTECTION-TINTED	
0437244	CN-215-2	DRIVER BLADE		0131680	XH-102-11	SPRING	
0408203	CN-220-2M	POPPET 0474429		0474429	XH-103-13	SCREW	
0408211	CN-220-3	POPPET SEAL		0483479	XH-108-18	WARNING LABEL	
0076828	CN-230-P2	MAG. BASE PARTIAL ASM.		0353847	XH-108-31	CYCLE LABEL	
0416933	CN-232-1	NEGATOR SPRING		1015413	XK-1173	PUSHER STOP KIT	
0437517	CN-240-3	WORK CONTACT ELEMENT		0456350	XO-1044-5	SPRING	
0437533	CN-240-10	STOP CAM BRACKET ASM.		0441162	XO-1055	PUSH ROD-LOWER	
0142240	CN-250-1	NOSE (MACHINED)		1011921	XO-1055-3B	TRIGGER	
1011786	CN-303-1	SCREW		0441204	XO-1055-4	TRIP LEVER	
1013911	CN-303-2	SCREW		0441212	XO-1055-5	BUSHING	
1011802	CN-306-1	WASHER		0441238	XO-1055-6	PUSH ROD-UPPER	
0065599	CN-308-3	PRODUCT LABEL		0441246	XO-1055-7	RETAINING RING	

\* = NEW PART > = PART CHANGE CN-3508 02/07 (24) GL

DROP-OFF	NAIL LENGTH	2" TO 2-1/2"	2 1/2" TO 3-3/4"
	PART NO.	CN-240-2	CN-140-2
	ITEM CODE	0440610	0435990



# CN-350B

## ROUND HEAD STRIP NAILER

### CLAVADORA DE CINTAS DE CABEZA REDONDA

The CN-350B is designed in compliance with American National Standards Institute, ANSI SNT-101-2002 and current applicable OSHA regulations.

La CLAVADORA CN-350B está diseñada en cumplimiento de las normas el Instituto Nacional de Normas Americanas ANSI SNT-101-2002 y los reglamentos actuales aplicables de OSHA.

**NOTE:** LOADING INSTRUCTIONS FOR THIS TOOL ARE LOCATED IN THE SAFETY, OPERATION, AND INSTRUCTION MANUAL.

**NOTA:** LAS INSTRUCCIONES DE CARGADO PARA ESTA HERRAMIENTA SE ENCUENTRAN EN EL MANUAL DE INSTRUCCIÓN Y OPERACIÓN SEGURA.

OPERATING AIR PRESSURE RANGE:	80-130 PSIG	5,52-8,96 BAR
MAXIMUM OPERATING PRESSURE:	130 PSIG	8,96 BAR

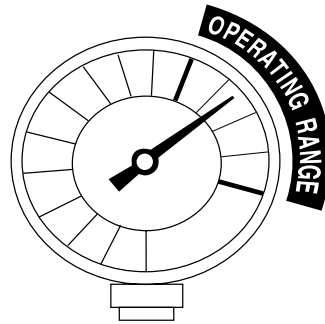

FREE AIR CONSUMPTION  
PER STROKE=

.089 cu. ft @ 80 psig/5.52 BAR

.099 cu. ft @ 90 psig/6.20 BAR

.113 cu. ft @ 100psig/6.89 BAR

CONSUMO DE AIRE LIBRE  
POR DISPARO=

2,5 Ltrs. @ 5,62 Kg/cm<sup>2</sup>

2,8 Ltrs. @ 6,33 Kg/cm<sup>2</sup>

3,2 Ltrs. @ 7,03 Kg/cm<sup>2</sup>

RANGO DE AIRE DE PRESIÓN DE FUNCIONAMIENTO = 5,62 Kg/cm<sup>2</sup> a 9,14 Kg/cm<sup>2</sup>  
PRESIÓN MÁXIMA DE FUNCIONAMIENTO = 9,14 Kg/cm<sup>2</sup>

FASTENER LOAD CAPACITY:

Two (2) strips "SL" Series round head strip nails from 2" to 3-3/4" long; .113 - .131 shank diameter.

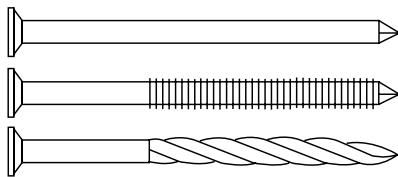

CAPACIDAD DE CARGA DE CLAVOS:

Dos (2) cintas de la Serie SL, de clavos de cabeza redonda desde 51 mm hasta 95 mm de largo y desde 0,113 hasta 0,131 mm diametro del clavo.

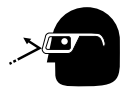

**SAFETY:** A pair of safety glasses that meets ANSI Z87.1 requirements must always be worn when using this tool. The use of proper eye protection has been shown to significantly reduce eye injuries. Complete safety training is available from your DUO-FAST representatives. It includes a wide range of safety materials to help keep safety awareness high throughout the work area.

**SEGURIDAD:** Un par de gafas de seguridad que cumplen con los requerimientos ANSI Z87.1 deber ser siempre usados con el uso de esta herramienta. El uso de protección ocular adecuada ha mostrado que reduce significativamente las lesiones oculares. Una capacitación completa sobre seguridad está disponible a través de sus representantes de DUO-FAST. La misma incluye una amplia gama de material sobre seguridad para ayudarlo a mantener un alto nivel de conciencia sobre la seguridad en toda el área de trabajo.



**WARRANTY:** Before buying or using any DUO-FAST tool, read the limited warranty that applies. For warranty details, see the full-line catalog or the warranty information in the tool carton.

**GARANTÍA:** Antes de comprar o utilizar cualquier herramienta DUO-FAST, lea la garantía limitada que se aplica. Para obtener detalles de la garantía consulte el catálogo de toda la línea o la información sobre la garantía en la caja de la herramienta.

**OPTIONAL EQUIPMENT AVAILABLE FOR THE CN-350B/EQUIPO OPCIONAL DISPONIBLE PARA LA CN-350B:**

CN-215-2B	OPTIONAL BLADE (1/8" shorter)	RK-204	O-RING KIT	XK-1022	NO-MAR KIT
RK-120	STANDARD TRIGGER KIT	RK-303	SEQ. TRIGGER KIT	XO-1043	YOKE EXTENSION
RK-200	CAP/TRIGGER KIT	XK-1016	HANGER KIT	XK-2029	SINGLE SEQ. KIT
		XK-1018	MUFFLER KIT		

**THE DROP OFF:** Purpose, selection, removal and assembly.

**DEL ALINEADOR:** Propósito, Selección, Retiro y Armado.

**PURPOSE:** The drop off of the CN-350B is located in the lower portion of the nose. It helps guide the nail straight as it comes free of the collated strip in the split second just prior to being driven into the workpiece. The guiding action helps prevent improperly driven nails and ricochets.

**PROPOSITO:** El alineador de la CN-350B esta ubicado en la parte inferior de la boquilla. Es una guía que ayuda mantener el clavo derecho en el instante en que este sale de la tira en la fraccion de segundo previa a su inserción. Esta ayuda a prevenir la inserción incorrecta de clavos y los rebotes.

**A DROP OFF MUST ALWAYS BE USED IN THE TOOL TO MINIMIZE IMPROPERLY DRIVEN OR RICOCHETING NAILS WHICH COULD CAUSE SERIOUS INJURY TO THE TOOL OPERATOR OR OTHER PERSONS IN THE WORK AREA.**

**SIEMPRE SE DEBE USAR UN ALINEADOR EN LA HERRAMIENTA PARA REDUCIR AL MINIMO LOS CLAVOS QUE SE INSERTAN INCORRECTAMENTE O QUE REBOTEN, LOS QUE PODRÍAN CAUSAR GRAVES HERIDAS AL APERADOR DE LA MAQUINA U A OTRAS PERSONAS EN EL AREA DE TRABAJO.**

**DROP OFF SELECTION:** When using nails from 2" TO 2-1/2" long , use the long drop off, DUO-FAST part# CN-240-2. When using nails from 2-3/4" to 3-3/4" long, use the short drop off, DUO-FAST part# CN-140-2.

**SELECCION:** Con clavos de 2" a 2-1/2" de largo, use un alineador largo numero de pieza DUO-FAST CN-240-2. Con clavos de 2-3/4" a 3-3/4" de largo, use un alineador corto, numero de pieza DUO-FAST Cn-140-2.

**REMOVAL:** The drop off is secured to the nose with two socket head cap screws. Using a 9/64" Allen wrench, loosen the two screws 1-1/2 turns. The drop off may now be pulled out of the track in the nose.

**RETIRO:** El alineador se asegura a la boquilla con dos tornillos de cabeza hueca. Con una llava Allen de 9/64", afloje los dos tornillos en un gito y medio. Jale el alineador para retirarlo de la pista de la boquilla.

**ASSEMBLY:** Select the correct drop off for the nails being used and slide it all the way into the track in the nose. Tighten the two screws with a 9/64" Allen wrench to secure the drop off in the nose.

**ARMADO:** Seleccione el alineador adecuado para el tipo de clavo que se esta usando y deslícelo completamente en la pista de la boquilla. Apriete los dos tornillos con una llave Allen de 9/64" para asegurar el alineador a la boquilla.

**CLEARING A JAM:****DES OBSTRUCCIÓN DE UN ATASCAMIENTO:**

Damaged parts, non-DUO-FAST manufactured fasteners and excessive dirt build up are the major causes of fastener jams.

Las piezas dañadas, los clavos que no hayan sido fabricados por DUO-FAST y el exceso de suciedad acumulada son las causas principales de que se traben clavos.

Follow this procedure if a jam should occur:

Siga este método si se produce un trabado:

- Disconnect air supply hose.
- Desconecte la manguera de suministro de aire.
- Remove all nails from tool.
- Quite todos los clavos de la herramienta.
- Push driver blade up with screwdriver or drift pin. An old driver blade may also be used.
- Empuje la cuchilla impulsora de la herramienta hacia arriba con un destornillador o cincel. También se puede usar una cuchilla impulsora vieja.
- The jammed nail can now be easily removed with a pair of pliers.
- El clavo trabado podrá quitarse ahora con facilidad con unas pinzas.
- Reload nails.
- Recargue los clavos.
- Reconnect air supply hose.
- Vuelva a conectar la manguera de suministro de aire.

**NOTE:** If tool continues to jam, take it out of service immediately and have it serviced by an authorized service center.

**NOTA:** Si la herramienta sigue trabándose, desconéctela inmediatamente y llévela a repararla a un centro de servicio autorizado.