

ICC Evaluation Service, Inc.  
[www.icc-es.org](http://www.icc-es.org)

**Business/Regional Office** ■ 5360 Workman Mill Road, Whittier, California 90601 ■ (562) 699-0543  
**Regional Office** ■ 900 Montclair Road, Suite A, Birmingham, Alabama 35213 ■ (205) 599-9800  
**Regional Office** ■ 4051 West Flossmoor Road, Country Club Hills, Illinois 60478 ■ (708) 799-2305

**DIVISION: 06—WOOD AND PLASTICS**  
**Section: 06095—Nails**

**REPORT HOLDER:**

INTERNATIONAL STAPLE, NAIL AND TOOL ASSOCIATION  
512 WEST BURLINGTON AVENUE, SUITE 203  
LAGRANGE, ILLINOIS 60525-2245  
(708) 482-8138  
[www.isanta.org](http://www.isanta.org)  
[isanta@ameritech.net](mailto:isanta@ameritech.net)

**EVALUATION SUBJECT:**

**POWER-DRIVEN STAPLES AND NAILS**

**ADDITIONAL LISTEES:**

“DUBAI WIRE”—BRAND NAME  
DUBAI WIRE FZE  
POST OFFICE BOX 11871  
JEBEL ALI  
DUBAI, UNITED ARAB EMIRATES

“HITACHI”—BRAND NAME  
HITACHI KOKI U.S.A., LTD.  
3950 STEVE REYNOLDS BOULEVARD  
NORCROSS, GEORGIA 30093

“MASTER FASTENERS”—BRAND NAME  
MASTER FASTENERS INTERNATIONAL, LLC  
4726 EAST 26<sup>TH</sup> STREET  
VERNON, CALIFORNIA 90040

“PREBENA”—BRAND NAME  
PREBENA AMERICA/NORTH AMERICAN FASTENER  
CORP.  
ROUTE 1, BOX 47A  
BRIDGEPORT, WEST VIRGINIA 26330

“GRIP-RITE,” “PRIMEAIR” AND “FAS’NERS  
UNLIMITED”—BRAND NAMES  
PRIMESOURCE BUILDING PRODUCTS  
2115 EAST BELTLINE ROAD  
CARROLLTON, TEXAS 75006

“STANLEY-ALLSPECS,” “STANLEY-BOSTITCH” AND  
“STAN-TECH”—BRAND NAMES  
STANLEY FASTENING SYSTEMS  
EAST GREENWICH, RHODE ISLAND 02818

“TREE ISLAND,” “HALSTEEL” AND “IWP-GOLDEN  
STATE”—BRAND NAMES  
TREE ISLAND INDUSTRIES LTD.  
POST OFFICE BOX 50  
NEW WESTMINSTER, BRITISH COLUMBIA V3L 4Y1  
CANADA

“FALCON”—BRAND NAME  
FALCON FASTENERS REG'D  
251 NANTUCKET BOULEVARD  
TORONTO, ONTARIO M1P 2P2  
CANADA

“FASCO” AND “FASCO/BECK”—BRAND NAMES  
FASCO AMERICA, INC.  
105 INDUSTRIAL PARK DRIVE  
MUSCLE SHOALS, ALABAMA 35661

“GERDAU AMERISTEEL”—BRAND NAME  
GERDAU AMERISTEEL - ATLAS STEEL AND WIRE  
LOCATION  
325 HORD STREET  
NEW ORLEANS, LOUISIANA 70123

“MAX”—BRAND NAME  
MAX USA CORP.  
257 EAST 2<sup>ND</sup> STREET  
MINEOLA, NEW YORK 11501

“PASLODE” AND “DUO-FAST”—BRAND NAMES  
PASLODE,  
AN ILLINOIS TOOL WORKS COMPANY  
888 FOREST EDGE DRIVE  
VERNON HILLS, ILLINOIS 60061

“SPECIALTY FASTENERS”—BRAND NAME  
SPECIALTY FASTENING SYSTEMS, INC.  
424 SOUTH BAGGETT  
PRAIRIE GROVE, ARKANSAS 72753

**1.0 EVALUATION SCOPE**

**Compliance with the following codes:**

- 2003 *International Building Code*® (IBC)
- 2003 *International Residential Code*® (IRC)
- BOCA® *National Building Code*/1999 (BNBC)
- 1999 *Standard Building Code*® (SBC)
- 1997 *Uniform Building Code*™ (UBC)
- 1998 *International One and Two Family Dwelling Code*® (IOTFDC)

\*Revised May 2005

ES REPORTS™ are not to be construed as representing aesthetics or any other attributes not specifically addressed, nor are they to be construed as an endorsement of the subject of the report or a recommendation for its use. There is no warranty by ICC Evaluation Service, Inc., express or implied, as to any finding or other matter in this report, or as to any product covered by the report.



**Properties evaluated:**

Structural connections

**2.0 USES**

The nails and staples described in this report are used for engineered and nonengineered connections.

**3.0 DESCRIPTION****3.1 General:**

The fasteners described in this report are manufactured by the member companies of the International Staple, Nail and Tool Association listed in this report. Appendix B of this report lists the fasteners recognized for each listee. Portions of this report were previously recognized in evaluation reports NER-272 and ER-2403.

**3.2 Staples:**

**3.2.1 General:** The staples are manufactured from No. 18 [0.0475 inch (1.21 mm)], No. 16 [0.0625 inch (1.59 mm)], No. 15 [0.072 inch (1.83 mm)] and No. 14 [0.080 inch (2.03 mm)] gage, round, semi-flattened or flattened, plain or zinc-coated steel wire, and are driven with power tools. The staples are available with outside crown widths varying from  $\frac{3}{16}$  inch to 1 inch (4.8 mm to 25 mm). Leg lengths vary from  $\frac{5}{8}$  inch to  $3\frac{1}{2}$  inches (15.9 mm to 89 mm). The staples are collated into strips and coated with polymer coatings. Staples manufactured from aluminum and copper wire are permitted in nonstructural applications only when specifically recognized in the attachments as set forth in Tables 45, 46 and 47 of this report. Staple crown widths and leg lengths specified in this report are overall dimensions.

**3.2.2 Staple Bending Moments (M):** For engineered and structural construction, steel staples with the minimum bending moment are required. No. 16 gage staples shall have a minimum average bending moment of 3.6 in.-lbs. (0.41 N-m); No. 15 gage staples shall have a minimum average bending moment 4.0 in.-lbs. (0.45 N-m); and No. 14 gage staples shall have a minimum average bending moment 4.3 in.-lbs. (0.49 N-m). Staples meeting these requirements are identified in Appendix B.

**3.3 Nails:**

**3.3.1 General:** Nails are manufactured from plain steel wire, galvanized steel wire, aluminum wire, copper wire or stainless steel wire. Aluminum and copper nails are permitted in nonstructural applications only when specifically recognized in Table 46 of this report. Nail heads include full round heads or modified round heads such as clipped heads, "D" heads, notched heads, oval heads or T-shaped heads. Nails are supplied with smooth or deformed (threaded) shanks. Deformed shanks may be annularly threaded (ring shank) or helically threaded (screw shank). Nails are collated and cohered into strips, clips or coils for loading into a power driving tool. Nails with T-shaped heads are permitted in nonstructural connections only when specifically recognized in the tables of this report. Examples of common nail head and shank styles, and other fastener designs, are illustrated in Figure 1. Minimum dimensions govern fastener recommendations. The pennyweight and style of commonly used nails are described in the accompanying tables. Table 1 lists shank lengths and diameters for the nails.

**3.3.2 Nail Bending Yield Strength ( $F_{yb}$ ):** For engineered and structural construction, steel nails meeting the minimum bending yield strength are required. Nails formed from steel wire having a nominal diameter of 0.135 inch (3.4 mm) or less shall have a minimum average bending yield strength of 100 ksi (689 MPa), and nails with diameters greater than 0.135 inch (3.4 mm) shall have a minimum average bending yield strength of 90 ksi (620 MPa). The 20d common nails

described in Tables 25 and 26 shall have a minimum average bending yield strength of 80 ksi (55 MPa). Nails meeting these requirements are identified in Appendix B.

**3.4 Coatings:**

The coatings used consist of thermoplastic plastics. Coated fasteners meet or exceed the holding power of uncoated fasteners, and therefore are alternatives to any uncoated fastener listed in this report.

For construction to ICC's SBCCI SSTD 10, fasteners exposed directly to the weather or subject to salt corrosion in coastal areas, as determined by the code official, shall be stainless steel or hot dip galvanized after fabrication to 1 ounce per square foot (305 g/m<sup>2</sup>).

For construction to UBC Appendix Section 2337, fasteners in exposed locations or in areas otherwise subject to corrosion shall have a corrosion resistance equal to or greater than a hot-dipped galvanized coating of 1.5 ounces of zinc per square foot (458 g/m<sup>2</sup>) of surface area.

**3.5 Conformance to the ANSI/AF&PA NDS (National Design Specification®):**

The fastening schedules in this report have lateral strength equal to or exceeding the lateral strength of connections found in the model codes. Tabulated fastener nominal design values are based on the yield mode equations shown in Appendix A of this report. The NDS-2001 is referenced in Section 2306.1 of the IBC, and in Sections R502.2, R602.3 and R802.2 of the IRC. The NDS-1997 is referenced in Section 2303.1.1 of the NBC and Section 2301.2.5 of the SBC. The NDS-91 is referenced in Section 2316 of the UBC and Section 802.2 of the IOTFDC.

**3.6 Fastener Tolerances:**

The staples and nails recognized in Appendix B of this report conform to the tolerances specified in ASTM F 1667, "Standard Specification for Driven Fasteners: Nails, Spikes, and Staples."

**4.0 INSTALLATION****4.1 General:**

Nail and staple installation shall comply with the tables in this report. Nail installation shall comply with the and applicable requirements of the model codes.

**4.2 Hardened Screw-shank Steel Nails:**

For attaching subflooring to 0.047-inch [No. 14 gage (1.19 mm)] steel floor joists, collated hardened screw shank nails shall have a minimum shank diameter of 0.120 inch (3.05 mm) with diamond points. The screw shank flutes of the nail shall begin a maximum distance of  $\frac{1}{2}$  inch (12.7 mm) from the underside of the nail head and continue to the top of the nail point. Interruptions in shank deformation are permitted to improve/allow adherence to shank of the medium cohering nails into a strip, clip or coil. The nails shall be driven with a power tool for the attachment of subflooring directly to 0.047-inch [No. 14 gage (1.19 mm)] steel floor joists, providing a minimum penetration through the steel floor joist of  $\frac{1}{2}$  inch (12.7 mm). Nail spacing for plywood is 6 inches (152 mm) on center at intermediate supports. Two nails per board are required for tongue-and-groove sheathing.

**5.0 CONDITIONS OF USE**

The nails and staples described in this report comply with, or are suitable alternatives to what is specified in, those codes listed in Section 1.0 of this report, subject to the following conditions:

- 5.1** The crown width, leg length and gage of staples, and the shank length and diameter of nails, specified in this report, are minimum nominal dimensions. When fasteners larger than those specified are used for any application, consideration shall be given to restrictions on edge distance and close spacing of large-diameter nails described in the diaphragm tables.
- 5.2** Diaphragm and other construction noted in this report shall conform to all applicable provisions of the applicable code.
- 5.3** All staples attaching diaphragm and nondiaphragm structural-use panels or 1-inch (25.4 mm) nominal sheathing shall be installed with the crowns of the staple parallel to the long dimension of the framing members, and be driven flush with the surface of the sheathing. The spacing, wire gage and leg lengths of the fasteners shall be as set forth in this report.
- 5.4** Steel nails with T-shaped heads, all aluminum and copper nails, and staples with crowns less than  $\frac{7}{16}$  inch (11.1 mm) wide are permitted in nonstructural connections only when specifically recognized in Tables 46, 47 and 48 of this report.
- 5.5** For construction to ICC's SBCCI SSTD 10, fasteners exposed directly to the weather or subject to salt corrosion in coastal areas, as determined by the building official, shall be stainless steel or hot dip galvanized after fabrication to 1 ounce per square foot (305 g/m<sup>2</sup>).
- 5.6** For construction to UBC Appendix Section 2337, fasteners in exposed locations or in areas otherwise

subject to corrosion shall have a corrosion resistance equal to or greater than a hot-dipped galvanized coating of 1.5 ounces of zinc per square foot (458 g/m<sup>2</sup>) of surface area.

- 5.7** Use of fasteners in chemically treated wood, such as preservative-treated or fire-retardant-treated wood, is outside the scope of this report.

## **6.0 EVIDENCE SUBMITTED**

- 6.1** Data in accordance with the ICC-ES Acceptance Criteria for Nails and Spikes (AC116), dated February 2005.
- 6.2** Data in accordance with the ICC-ES Acceptance Criteria for Staples (AC201), dated July 2002.
- 6.3** Quality control manuals for each manufacturing facility.

## **7.0 IDENTIFICATION**

Containers of nails and staples shall be identified with the name of one of the listees identified in this report, part identification, nail size, quantity, and the evaluation report number (ESR-1539).

Coated fasteners are identified on the fastener carton or other packaging material by the word "coated," or by a trade name implying a coating.

Fasteners recognized in Appendix B for corrosion resistance shall be labeled "ASTM A 153" or "ASTM A 641, Class 1", or be marked with the coating weight.

## CONTENTS

Table No.		Page
	Basic Fastener Style Guide . . . . .	5
1	Nominal Dimensions of Nails Frequently Listed in Model Building Codes . . . . .	6
	<b><u>“Design” Values and Allowable Load Tables</u></b>	
	<u>Staple &amp; Nail Values for Structural Design</u>	
2	Withdrawal Design Values . . . . .	7
3	Normal Design Lateral Strength of Face-Nailed Connections of “2-by” Members to Other Members of the Same Species . . . . .	8
	<u>Horizontal Diaphragms</u>	
	Allowable Shear for Wind or Seismic Loading for Structural Panel Horizontal Diaphragms	
4	5/16" Thick Structural I Sheathing . . . . .	9
5	3/8" Thick Structural I Sheathing . . . . .	10
6	15/32" Thick Structural I Sheathing . . . . .	11
7	5/16" Thick Rated Sheathing . . . . .	12
8	3/8" Thick Rated Sheathing . . . . .	13
9	7/16" Thick Rated Sheathing . . . . .	14
10	15/32" Thick Rated Sheathing . . . . .	15
11	19/32" Thick Rated Sheathing . . . . .	16
	<u>Shear Walls</u>	
	Allowable Shear for Wind or Seismic Loading for Structural Panel Shear Walls	
12	5/16" Thick Structural I Sheathing . . . . .	18
13	3/8" Thick Structural I Sheathing . . . . .	19
14	7/16" Thick Structural I Sheathing . . . . .	20
15	15/32" Thick Structural I Sheathing . . . . .	21
16	5/16" Thick Rated Sheathing . . . . .	22
17	3/8" Thick Rated Sheathing . . . . .	23
18	7/16" Thick Rated Sheathing . . . . .	24
19	15/32" Thick Rated Sheathing . . . . .	25
20	19/32" Thick Rated Sheathing . . . . .	26
	<u>Vertical Diaphragms of Wall Sheathing</u>	
	Allowable Shear for Wind or Seismic Loading for Vertical Diaphragms of Wall Sheathing of	
21	5/16" and 3/8" Plywood Panel Siding. . . . .	28
22	Gypsum Lath-Plaster, Wallboard and Exterior Plaster Attached to Wood-Framed Wall Assemblies . . . . .	29
	<b><u>Prescriptive Minimum Fastening Schedule Tables</u></b>	
	<u>Framing</u>	
23	Wall . . . . .	30
24	Ceiling and Roof . . . . .	32
25	Floor . . . . .	34
26	Summary of Fasteners for Framing . . . . .	36
	<u>Prescriptive Sheathing Tables</u>	
27	Combination Subfloor/Underlayment to Wood Framing Members . . . . .	38
	How to Use the Prescriptive Sheathing Tables . . . . .	39
	Model Code Requirements for Roof Sheathing	
28	BOCA National Building Code, Nailing . . . . .	40
29	BOCA National Building Code, Stapling . . . . .	41
30	International Building Code . . . . .	41
31	International Residential Code & International One & Two Family Dwelling Code . . . . .	42
32	Standard Building Code . . . . .	42
33	SBCCI Standard for Hurricane Resistant Residential Construction . . . . .	43
34	Uniform Building Code . . . . .	44
35	Model Code Requirements for Wall Sheathing . . . . .	45
	Model Code Requirements for Subfloor Sheathing	
36	BOCA National, Standard and Uniform Codes . . . . .	46
37	International Codes . . . . .	47
	Alternate Sheathing Fastenings to the Use of	
38	6d Box Nails for ½" and Thinner Wall Sheathing . . . . .	48
39	6d Common Nails for ½" and Thinner Sheathing . . . . .	49

40	8d Common Nails for 1/2" and Thinner Sheathing	50
41	8d Deformed Shank Nails for 1/2" and Thinner Sheathing	51
42	8d Box Nails for 19/32", 5/8", 23/32" and 3/4" Wall Sheathing	52
43	8d Common Nails for 19/32", 5/8", 23/32" and 3/4" Sheathing	53
44	8d Deformed Shank Nails for 19/32", 5/8", 23/32" and 3/4" Sheathing	54
<u>Other General Attachments</u>		
45	Wall Sheathing, Panel Siding and Floor Underlayment	55
46	Wall and Roof Coverings	56
47	Wall, Ceiling and Soffit Covering Materials Attached to Wood Receiving Members	57
48	Wall, Ceiling and Soffit Covering Materials Attached to Metal Receiving Members	58
<u>Appendix A</u>		59
<u>Appendix B</u>		64

**FIGURE 1  
BASIC FASTENER STYLES**

Smooth Shank Nail



Ring Shank Nail



Screw Shank Nail



Staple

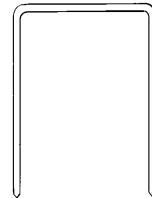

Nail Head Styles

Round

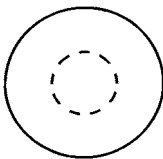

Offset

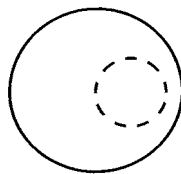

Oval

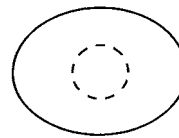

Clipped

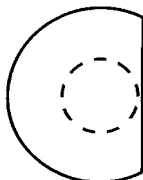

Notched

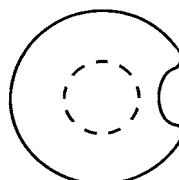

**TABLE 1  
NOMINAL DIMENSIONS OF NAILS FREQUENTLY LISTED IN  
MODEL BUILDING CODES AND THIS REPORT**

Nails Described by Pennyweight System		
Pennyweight	Length, in inches	Shank Diameter, in inches
Box		
6d	2	0.099
8d	2½	0.113
10d	3	0.128
Casing		
6d	2¼	0.099
8d	2½	0.113
10d	3	0.128
Common		
6d	2	0.113
8d	2½	0.131
10d	3	0.148
16d	3½	0.162
20d	4	0.192
Cooler		
5d	1⅝	0.086
6d	1⅞	0.092
8d	2⅞	0.113
Deformed <sup>1</sup>		
3d	1¼	0.099
4d	1½	0.099
6d	2	0.120
8d	2½	0.120
Finish		
8d	2½	0.099
10d	3	0.113
Siding		
6d	1⅞	0.106
8d	2⅞	0.128
Additional Recognized Nails		
Smooth Shank Nails	2¼	0.092
	2¼	0.105
	3	0.120
	3¼	
	1½	0.131
	3	
	3¼	
	1½	0.148
2 ½	0.162	
Deformed Shank Nails <sup>1</sup>	2¼	0.099
	2	0.113
	2⅞	
	2½	0.131

<sup>1</sup>A deformed shank nail shall have either a helical (screw) shank or an annular (ring) shank.

**TABLE 2  
NAIL AND STAPLE NORMAL WITHDRAWAL DESIGN VALUES<sup>1,2,3,4</sup>, POUNDS PER INCH OF PENETRATION**

Specific Gravity <sup>6</sup>	Smooth shank nails, diameter in inches						Deformed shank <sup>5</sup> nails, diameter in inches						Staple Gage and Diameter, in inches							
	0.091	0.094	0.097	0.105	0.113	0.120	0.131	0.148	0.162	0.091	0.094	0.097	0.113	0.120	0.128	0.135	0.148	16 gage	15 gage	14 gage
0.31	7	7	7	8	8	9	10	11	12	7	8	8	9	10	10	11	12	9	11	12
0.35	9	9	10	11	11	12	13	15	16	10	10	11	12	13	14	15	16	13	14	16
0.36	10	10	10	11	12	13	14	16	17	11	11	11	13	14	15	16	17	13	15	17
0.37	10	11	11	12	13	14	15	17	19	12	12	12	14	15	16	17	19	14	17	18
0.38	11	12	12	13	14	15	16	18	20	12	13	13	15	16	17	18	20	15	18	20
0.39	12	12	13	14	15	16	17	19	21	13	14	14	16	17	18	19	21	16	19	21
0.4	13	13	14	15	16	17	18	21	23	14	14	15	17	18	20	21	23	17	20	22
0.41	14	14	14	16	17	18	19	22	24	15	15	16	18	20	21	22	24	19	21	24
0.42	14	15	15	17	18	19	21	23	26	16	16	17	20	21	22	23	26	20	23	25
0.43	15	16	16	18	19	20	22	25	27	17	17	18	21	22	24	25	27	21	24	27
0.44	16	17	17	19	20	21	23	26	29	18	18	19	22	23	25	26	29	22	26	28
0.46	18	19	19	21	22	24	26	29	32	20	20	21	25	26	28	29	32	25	29	32
0.47	19	20	20	22	24	25	27	31	34	21	22	22	26	28	29	31	34	26	30	33
0.49	21	22	22	24	26	28	30	34	38	23	24	25	29	31	33	34	38	29	33	37
0.5	22	23	24	26	28	29	32	36	40	24	25	26	30	32	34	36	40	30	35	39
0.51	23	24	25	27	29	31	34	38	42	26	27	27	32	34	36	38	42	32	37	41
0.55	28	29	30	33	35	37	41	46	50	31	32	33	38	41	44	46	50	39	45	50
0.58	32	33	34	37	40	42	46	52	57	35	37	38	44	47	50	53	58	44	51	57
0.67	46	48	49	53	57	61	66	75	82	51	52	54	63	67	71	75	83	63	73	81
0.68	48	49	51	55	59	63	69	78	85	53	54	56	65	69	74	78	86	66	76	84
0.71	53	55	57	62	66	70	77	87	95	59	61	63	73	77	83	87	95	73	84	94
0.73	57	59	61	66	71	75	82	93	102	63	65	67	78	83	88	93	102	79	90	101

<sup>1</sup>Design values are based on a normal (10 year) duration of load.

<sup>2</sup>Table values shall be multiplied by applicable adjustment factors such as for load duration, wet service, temperature, and toe-nailing.

<sup>3</sup>Withdrawal strengths are for fasteners driven perpendicular to the grain.

<sup>4</sup>For connections between solid lumber members, the permitted withdrawal strength of fasteners shall be limited to two times the tabulated values, regardless of increased penetrations. For connections between wood structural panels and solid lumber with a specific up to 0.51, the permitted withdrawal strength shall be limited to 1.34 times the tabulated values regardless of penetration. For connections between wood structural panels and solid lumber with specific gravity of 0.55 or greater, permitted withdrawal strength is limited to 1.17 times the tabulated values at 0.55 specific gravity, regardless of increased penetration or greater specific gravity.

<sup>5</sup>A deformed shank (threaded) nail shall have either a helical (screw) shank or an annular (ring) shank.

<sup>6</sup>Specific gravity (G) values for common species are listed in Appendix A of this report.

**TABLE 3**  
**NORMAL <sup>1</sup> DESIGN <sup>2</sup> LATERAL STRENGTH OF FACE NAILED SINGLE SHEAR CONNECTIONS OF**  
**"2-BY" MEMBERS <sup>3</sup> TO OTHER MEMBERS <sup>4</sup> OF SAME SPECIES <sup>5</sup>**

Fastener		Connection Lateral Strength, in Pounds, if Both Framing Members Have Specific Gravity of . . .			
Length (Inches)	Nail Shank Diameter <sup>6</sup> (Inches)	0.42 (e.g., Spruce-Pine-Fir)	0.43 (e.g., Hem-Fir)	0.50 (e.g., Douglas Fir-larch)	0.55 (e.g. Southern Pine)
3½	0.162	92	94	109	119
3	0.148	84	86	99	109
3¼	0.131	79	80	93	101
3	0.131	79	80	93	101
2½	0.131	52	54	62	67
3¼	0.120	69	71	81	89
3	0.120	69	71	81	89
2¾	0.113	40	40	47	51
2¼	0.105	30	31	37	41
2¼	0.099	30	30	35	38

<sup>1</sup>Design values are based on a 10-year "normal" load duration.

<sup>2</sup>Table values shall be multiplied by applicable adjustment factors such as for load duration, wet service, temperature, and toenailing.

<sup>3</sup>Table is based upon a 1½" actual thickness of both attached member and receiving ("main") member.

<sup>4</sup>Design values are for connections in which the nail shank or staple leg are driven in side grain with shank/leg axis perpendicular to wood fibers. Tabulated values for nailed connections require that the nail has a minimum fastener bending yield strength ( $F_{yb}$ ) as that listed in Section 3.3.2 of this report.

<sup>5</sup>Calculations are based on a connection in which both members have the same specific gravity. The "European Yield Model" formulas in Appendix A permit calculation of the design lateral strength for connections consisting of different wood species.

<sup>6</sup>Nails shall have a smooth shank or deformed shank - with helical (screw) or annular (ring) threads.

**TABLE 4**  
**ALLOWABLE SHEAR<sup>1</sup> FOR WIND OR SEISMIC LOADING (POUNDS PER FOOT) FOR**  
**WOOD STRUCTURAL PANEL HORIZONTAL DIAPHRAGMS WITH FRAMING OF**  
**DOUGLAS-FIR, LARCH, OR SOUTHERN PINE<sup>2</sup>**  
**5/16" THICK STRUCTURAL I PANEL GRADE<sup>11</sup>**

Nominal Nail <sup>4</sup> Diameter <sup>6</sup> (in inches) or Staple <sup>5</sup> Gage	Minimum Nominal Fastener Length <sup>6</sup> (in inches)	Minimum Width of Framing Member (in inches)	Blocked Diaphragms				Unblocked Diaphragms	
			Fastener spacing (in.) at diaphragm boundaries (all cases), at continuous panel edges parallel to load (Cases 3, 4), and at all panel edges (Cases 5 & 6) <sup>7</sup>				Fasteners spaced 6" max. at supported edges <sup>7</sup>	
			6	4	2½ <sup>8</sup>	2 <sup>8</sup>	Case 1 (No unblocked edges or continuous joints parallel to load)	All other configurations (Cases 2, 3, 4, 5 & 6)
			Nail spacing at other panel edges (Cases 1, 2, 3 & 4) <sup>7</sup>					
6	6	4	3					
0.113 smooth or deformed	1⅝ 2 or 2⅜	2 3	185 210	250 280	375 420	420 475	165 185	125 140
0.120 smooth	3							
14 Gage	3 2½ 2¼ or 2							
15 Gage	2½ 2¼ 2 or 1¾							
16 Gage	2 1¾ or 1½	2 3	155 175	205 230	310 345	350 390	135 155	105 115
0.099 smooth or deformed	2¼	2 3	145 165	195 220	295 330	335 375	130 145	100 110
0.092 smooth	2¼	2 3	130 145	170 195	260 290	290 330	115 125	85 95

See page 18 for footnote explanations and load diagrams.

**TABLE 5**  
**ALLOWABLE SHEAR<sup>1</sup> FOR WIND OR SEISMIC LOADING (POUNDS PER FOOT) FOR**  
**WOOD STRUCTURAL PANEL HORIZONTAL DIAPHRAGMS WITH FRAMING OF**  
**DOUGLAS-FIR, LARCH, OR SOUTHERN PINE<sup>2</sup>**  
**3/8" THICK STRUCTURAL I PANEL GRADE<sup>11</sup>**

Nominal Nail <sup>4</sup> Diameter <sup>6</sup> (in inches) or Staple <sup>5</sup> Gage	Minimum Nominal Fastener Length <sup>6</sup> (in inches)	Minimum Width of Framing Member (in inches)	Blocked Diaphragms				Unblocked Diaphragms	
			Fastener spacing (in.) at diaphragm boundaries (all cases), at continuous panel edges parallel to load (Cases 3, 4), and at all panel edges (Cases 5 & 6) <sup>7</sup>				Fasteners spaced 6" max. at supported edges <sup>7</sup>	
			6	4	2½ <sup>8</sup>	2 <sup>8</sup>	Case 1 (No unblocked edges or continuous joints parallel to load)	All other configurations (Cases 2, 3, 4, 5 & 6)
			Nail spacing at other panel edges (Cases 1, 2, 3 & 4) <sup>7</sup>					
6	6	4	3					
0.131 smooth or deformed	1⅞ or 2½	2 3	270	360	530	600	240	180
			300	400	600	675	265	200
0.120 smooth	3	2 3	230	305	455	515	200	150
			255	340	510	580	225	170
0.113 smooth or deformed	2⅞ or 2	2 3	205	275	410	465	180	135
			230	305	460	520	205	155
0.099 smooth or deformed	2¼	2 3	165	215	325	370	145	110
			185	245	365	415	160	120
0.092 smooth	2¼	2 3	145	190	290	325	130	95
			160	215	325	365	145	110
14 Gage	3 2½ 2¼ or 2	2 3	255	340	510	580	225	170
			285	380	575	645	255	190
15 Gage	2½ or 2¼ 2 or 1¾	2 3	220	290	435	495	195	145
			245	325	490	555	215	165
16 Gage	2 1¾ or 1½	2 3	175	235	350	400	155	115
			200	265	395	450	175	130

See page 18 for footnote explanations and load diagrams.

**TABLE 6**  
**ALLOWABLE SHEAR<sup>1</sup> FOR WIND OR SEISMIC LOADING (POUNDS PER FOOT)**  
**FOR WOOD STRUCTURAL PANEL HORIZONTAL DIAPHRAGMS WITH FRAMING OF**  
**DOUGLAS-FIR, LARCH, OR SOUTHERN PINE<sup>2</sup>**  
**15/32-INCH-THICK STRUCTURAL I PANEL GRADE<sup>10,11</sup>**

Nominal Nail <sup>4</sup> Diameter <sup>6</sup> (in inches) or Staple <sup>5</sup> Gage	Minimum Nominal Fastener Length <sup>6</sup> (in inches)	Minimum Width of Framing Member (in inches)	Blocked Diaphragms				Unblocked Diaphragms	
			Fastener spacing (in.) at diaphragm boundaries (all cases), at continuous panel edges parallel to load (Cases 3, 4), and at all panel edges (Cases 5 & 6) <sup>7</sup>				Fasteners spaced 6" max. at supported edges <sup>7</sup>	
			6	4	2½ <sup>8</sup>	2 <sup>8</sup>	Case 1 (No unblocked edges or continuous joints parallel to load)	All other configurations (Cases 2, 3, 4, 5 & 6)
			Nail spacing at other panel edges (Cases 1, 2, 3 & 4) <sup>7</sup>					
6	6	4	3					
0.148 smooth <sup>9</sup>	2⅛ or 3	2 3	320	425	640	730	285	215
			360	480	720	820	320	240
0.131 smooth or deformed	2½	2 3	270	360	540	610	240	180
			305	405	605	685	270	200
0.120 smooth	3	2 3	230	310	465	525	205	155
			260	350	520	590	230	175
0.113 smooth or deformed	2⅜	2 3	210	280	420	475	185	140
0.113 smooth or deformed	2		235	315	470	535	210	155
0.099 smooth or deformed	2¼	2 3	170	225	340	385	150	115
			190	255	380	435	170	125
0.092 smooth	2¼	2 3	150	205	305	345	135	100
			170	230	340	390	150	115
14 Gage	3 or 2½ 2¼ or 2	2 3	255	340	510	575	225	170
			285	380	570	650	255	190
15 Gage	2½ 2¼ 2 or 1¾	2 3	215	290	435	495	195	145
			245	325	490	555	215	165
16 Gage	2 1¾ or 1½	2 3	175	235	350	400	155	120
			200	265	395	450	175	130

See page 18 for footnote explanations and load diagrams.

**TABLE 7**  
**ALLOWABLE SHEAR <sup>1</sup> FOR WIND OR SEISMIC LOADING (POUNDS PER FOOT) FOR**  
**WOOD STRUCTURAL PANEL HORIZONTAL DIAPHRAGMS WITH FRAMING OF**  
**DOUGLAS-FIR, LARCH, OR SOUTHERN PINE <sup>2</sup>**  
**5/16" THICK RATED SHEATHING <sup>3,11</sup>**

Nominal Nail <sup>4</sup> Diameter <sup>6</sup> (in inches) or Staple <sup>5</sup> Gage	Minimum Nominal Fastener Length <sup>6</sup> (in inches)	Minimum Width of Framing Member (in inches)	Blocked Diaphragms				Unblocked Diaphragms	
			Fastener spacing (in.) at diaphragm boundaries (all cases), at continuous panel edges parallel to load (Cases 3, 4), and at all panel edges (Cases 5 & 6) <sup>7</sup>				Fasteners spaced 6" max. at supported edges <sup>7</sup>	
			6	4	2½ <sup>8</sup>	2 <sup>8</sup>	Case 1 (No unblocked edges or continuous joints parallel to load)	All other configurations (Cases 2, 3, 4, 5 & 6)
			Nail spacing at other panel edges (Cases 1, 2, 3 & 4) <sup>7</sup>					
6	6	4	3					
0.113 smooth	2 or 1½	2 3	170 190	225 250	335 380	380 430	150 170	110 125
0.131 smooth or deformed	2½							
0.120 smooth	3							
0.113 smooth or deformed	2¾							
0.113 smooth or deformed	2							
14 Gage	3 2½ 2¼ or 2							
15 Gage	2½ 2¼ 2 or 1¾							
16 Gage	2 1¾ or 1½	2 3	140 155	185 205	275 310	315 350	125 140	90 105
0.099 smooth or deformed	2¼	2 3	130 150	175 200	265 295	300 335	120 130	90 100
0.092 smooth	2¼	2 3	115 130	155 175	230 260	265 295	105 115	75 85

See page 18 for footnote explanations and load diagrams.

**TABLE 8**  
**ALLOWABLE SHEAR<sup>1</sup> FOR WIND OR SEISMIC LOADING (POUNDS PER FOOT) FOR**  
**WOOD STRUCTURAL PANEL HORIZONTAL DIAPHRAGMS WITH FRAMING OF**  
**DOUGLAS-FIR, LARCH, OR SOUTHERN PINE<sup>2</sup>**  
**3/8" THICK RATED SHEATHING<sup>3,11</sup>**

Nominal Nail <sup>4</sup> Diameter <sup>6</sup> (in inches) or Staple <sup>5</sup> Gage	Minimum Nominal Fastener Length <sup>6</sup> (in inches)	Minimum Width of Framing Member (in inches)	Blocked Diaphragms				Unblocked Diaphragms	
			Fastener spacing (in.) at diaphragm boundaries (all cases), at continuous panel edges parallel to load (Cases 3, 4), and at all panel edges (Cases 5 & 6) <sup>7</sup>				Fasteners spaced 6" max. at supported edges <sup>7</sup>	
			6	4	2½ <sup>8</sup>	2 <sup>8</sup>	Case 1 (No unblocked edges or continuous joints parallel to load)	All other configurations (Cases 2, 3, 4, 5 & 6)
			Nail spacing at other panel edges (Cases 1, 2, 3 & 4) <sup>7</sup>					
6	6	4	3					
0.131 smooth or deformed	1⅞ or 2½	2 3	240 270	320 360	480 540	545 610	215 240	160 180
14 Gage	3 2½ 2¼ or 2	2 3	230 260	305 345	460 515	520 580	205 230	155 170
15 Gage	2½ 2¼ 2 or 1¾	2 3	195 220	260 295	390 440	445 495	175 195	130 145
0.120 smooth	3	2 3	210 235	280 315	420 470	475 530	185 210	140 155
0.113 smooth or deformed	1⅝ or 2 or 2⅜	2 3	185 210	250 280	375 420	425 475	165 185	125 140
16 Gage	2 1¾ or 1½	2 3	160 180	210 235	315 355	360 400	140 160	105 120
0.099 smooth or deformed	2¼	2 3	145 165	195 220	295 330	335 375	130 145	100 110
0.092 smooth	2¼	2 3	130 145	170 195	260 290	290 330	115 125	85 95

See page 18 for footnote explanations and load diagrams.

**TABLE 9**  
**ALLOWABLE SHEAR<sup>1</sup> FOR WIND OR SEISMIC LOADING (POUNDS PER FOOT) FOR**  
**WOOD STRUCTURAL PANEL HORIZONTAL DIAPHRAGMS WITH FRAMING OF**  
**DOUGLAS-FIR, LARCH, OR SOUTHERN PINE<sup>2</sup>**  
**7/16" THICK RATED SHEATHING<sup>3,11</sup>**

Nominal Nail <sup>4</sup> Diameter <sup>6</sup> (in inches) or Staple <sup>5</sup> Gage	Minimum Nominal Fastener Length <sup>6</sup> (in inches)	Minimum Width of Framing Member (in inches)	Blocked Diaphragms				Unblocked Diaphragms	
			Fastener spacing (in.) at diaphragm boundaries (all cases), at continuous panel edges parallel to load (Cases 3, 4), and at all panel edges (Cases 5 & 6) <sup>7</sup>				Fasteners spaced 6" max. at supported edges <sup>7</sup>	
			6	4	2½ <sup>8</sup>	2 <sup>8</sup>	Case 1 (No unblocked edges or continuous joints parallel to load)	All other configurations (Cases 2, 3, 4, 5 & 6)
			Nail spacing at other panel edges (Cases 1, 2, 3 & 4) <sup>7</sup>					
6	6	4	3					
0.131 smooth or threaded	2 or 2½	2 3	255	340	505	575	230 255	170 190
			285	380	570	645		
0.120 smooth	3	2 3	215	290	435	490	190 215	145 160
			245	325	485	550		
0.113 smooth or threaded	2¾ or 2	2 3	195	260	390	440	175 195	130 145
			220	290	435	490		
0.099 smooth or threaded	2¼	2 3	155	205	310	350	135 155	105 115
			170	230	345	395		
0.092 smooth	2¼	2 3	135	185	275	310	120 135	90 105
			155	205	310	350		
14 Gage	3 or 2½ 2¼ or 2	2 3	240	325	485	550	215 240	160 180
			270	365	545	615		
15 Gage	2½ 2¼ 2 or 1¾	2 3	205	275	415	470	185 205	140 155
			230	310	465	525		
16 Gage	2 1¾ or 1½	2 3	165	225	335	380	150 165	110 125
			190	250	375	425		

See page 18 for footnote explanations and load diagrams.

**TABLE 10**  
**ALLOWABLE SHEAR <sup>1</sup> FOR WIND OR SEISMIC LOADING (POUNDS PER FOOT) FOR**  
**WOOD STRUCTURAL PANEL HORIZONTAL DIAPHRAGMS WITH FRAMING OF**  
**DOUGLAS-FIR, LARCH, OR SOUTHERN PINE <sup>2</sup>**  
**15/32" THICK RATED SHEATHING <sup>3, 11</sup>**

Nominal Nail <sup>4</sup> Diameter <sup>6</sup> (in inches) or Staple <sup>5</sup> Gage	Minimum Nominal Fastener Length <sup>6</sup> (in inches)	Minimum Width of Framing Member (in inches)	Blocked Diaphragms				Unblocked Diaphragms	
			Fastener spacing (in.) at diaphragm boundaries (all cases), at continuous panel edges parallel to load (Cases 3, 4), and at all panel edges (Cases 5 & 6) <sup>7</sup>				Fasteners spaced 6" max. at supported edges <sup>7</sup>	
			6	4	2½ <sup>8</sup>	2 <sup>8</sup>	Case 1 (No unblocked edges or continuous joints parallel to load)	All other configurations (Cases 2, 3, 4, 5 & 6)
			Nail spacing at other panel edges (Cases 1, 2, 3 & 4) <sup>7</sup>					
6	6	4	3					
0.148 smooth <sup>9</sup>	2⅛ or 3	2 3	290	385	575	655	255	190
			325	430	650	735	290	215
0.131 smooth or deformed	2 or 2½	2 3	265	355	535	605	235	180
			300	400	600	680	265	200
0.120 smooth	3	2 3	230	305	455	515	200	150
			255	340	510	580	225	170
0.113 smooth or deformed	2⅜ or 2	2 3	205	275	410	465	180	135
			230	305	460	520	205	155
0.099 smooth or deformed	2¼	2 3	165	215	325	370	145	110
			185	245	365	415	160	120
0.092 smooth	2¼	2 3	145	190	290	325	130	95
			160	215	325	365	145	110
14 Gage	3 2½ 2¼ or 2	2 3	230	305	460	520	205	155
			260	340	515	585	230	170
15 Gage	2½ 2¼ 2 or 1¾	2 3	195	260	390	445	175	130
			220	290	440	500	195	145
16 Gage	2 1¾ or 1½	2 3	160	210	315	360	140	105
			180	235	355	405	160	120

See page 18 for footnote explanations and load diagrams.

**TABLE 11**  
**ALLOWABLE SHEAR<sup>1</sup> FOR WIND OR SEISMIC LOADING (POUNDS PER FOOT) FOR**  
**WOOD STRUCTURAL PANEL HORIZONTAL DIAPHRAGMS WITH FRAMING OF**  
**DOUGLAS-FIR, LARCH, OR SOUTHERN PINE<sup>2</sup>**  
**19/32" THICK RATED SHEATHING<sup>3, 10, 11</sup>**

Nominal Nail <sup>4</sup> Diameter <sup>6</sup> (in inches) or Staple <sup>5</sup> Gage	Minimum Nominal Fastener Length <sup>6</sup> (in inches)	Minimum Width of Framing Member (in inches)	Blocked Diaphragms				Unblocked Diaphragms	
			Fastener spacing (in.) at diaphragm boundaries (all cases), at continuous panel edges parallel to load (Cases 3, 4), and at all panel edges (Cases 5 & 6) <sup>7</sup>				Fasteners spaced 6" max. at supported edges <sup>7</sup>	
			6	4	2½ <sup>8</sup>	2 <sup>8</sup>	Case 1 (No unblocked edges or continuous joints parallel to load)	All other configurations (Cases 2, 3, 4, 5 & 6)
			Nail spacing at other panel edges (Cases 1, 2, 3 & 4) <sup>7</sup>					
6	6	4	3					
0.148 smooth <sup>9</sup>	2¼ or 3	2 3	320 360	425 480	640 720	730 820	285 320	215 240
0.131 smooth or deformed	2½	2 3	270 305	360 405	540 605	610 685	240 270	180 200
0.120 smooth	3	2 3	230 260	310 350	465 520	525 590	205 235	155 175
0.113 smooth or deformed	2¾ or 2	2 3	210 235	280 315	420 470	475 535	185 210	140 155
0.099 smooth or deformed	2¼	2 3	170 190	225 255	340 380	385 435	150 170	115 125
0.092 smooth	2¼	2 3	150 170	205 230	305 340	345 390	135 155	100 115
14 Gage	3 2½ 2¼ or 2	2 3	255 285	340 380	510 570	575 650	225 255	170 190
15 Gage	2½ 2¼ 2 or 1¾	2 3	215 245	290 325	435 490	495 555	195 215	145 165
16 Gage	2 1¾ or 1½	2 3	175 200	235 265	350 395	400 450	155 175	115 130

See page 18 for footnote explanations and load diagrams.

## Footnote Explanations for Horizontal Diaphragm Tables 4 - 11

1. Tabulated values are for short-time loading due to wind or earthquake and shall be reduced by 25 percent for normal loading based on a duration of load factor of 1.33 and a diaphragm factor of 1.3. For diaphragm deflection analysis, deflections in Appendix A, Table B or C shall be used.
2. The tabulated values are for fasteners installed in Douglas Fir-Larch or Southern Pine. Allowable values for diaphragms framed with wood having a specific gravity equal to or greater than 0.42 but less than 0.50 may be calculated by multiplying the values above by 0.82. For woods with specific gravity less than 0.42 multiply the values above by 0.65.
3. C-D, C-C Exterior Sheathing and other panel grades covered in PS 1 or PS 2.
4. Nails with "T," brad, finish or casing heads are not permitted. A deformed shank nail shall have either a helical (screw) shank or an annular (ring) shank.
5. Staples shall have a  $\frac{7}{16}$  inch minimum crown width.
6. Changes to fastener type, size or spacing shall be considered if diaphragms are required to withstand negative pressures of high winds or where prescribed in the model code. Prescriptive fastener schedules are summarized in Tables 28 to 37.
7. Values are based on 24" o.c. spacing of support framing members. Space fasteners maximum 12" o.c. along intermediate framing members (6 in. o.c. when supports are spaced 48" o.c.)
8. Framing at adjoining panel edges shall be 3-inch nominal or wider and nails shall be staggered where nails are spaced  $2\frac{1}{2}$ " or closer on center.
9. Framing at adjoining panel edges shall be 3-inch nominal or wider and nails shall be staggered where nails with shank diameters of 0.148" or greater and penetration of  $1\frac{5}{8}$  inches or greater are placed 3 inches on center or closer.
10. Plywood not exceeding  $1\frac{1}{8}$ " in thickness is permitted to be attached provided the fastener penetration is at least twelve times the fastener shank diameter.
11. In addition to requirements presented above for fastening of horizontal diaphragms all other requirements of the applicable model code (such as, but not limited to, conditions of use and modification of design values for certain Seismic Design Categories) pertaining to horizontal diaphragm design and construction shall be met.

Load Diagrams for Horizontal Diaphragm Tables 4 - 11.

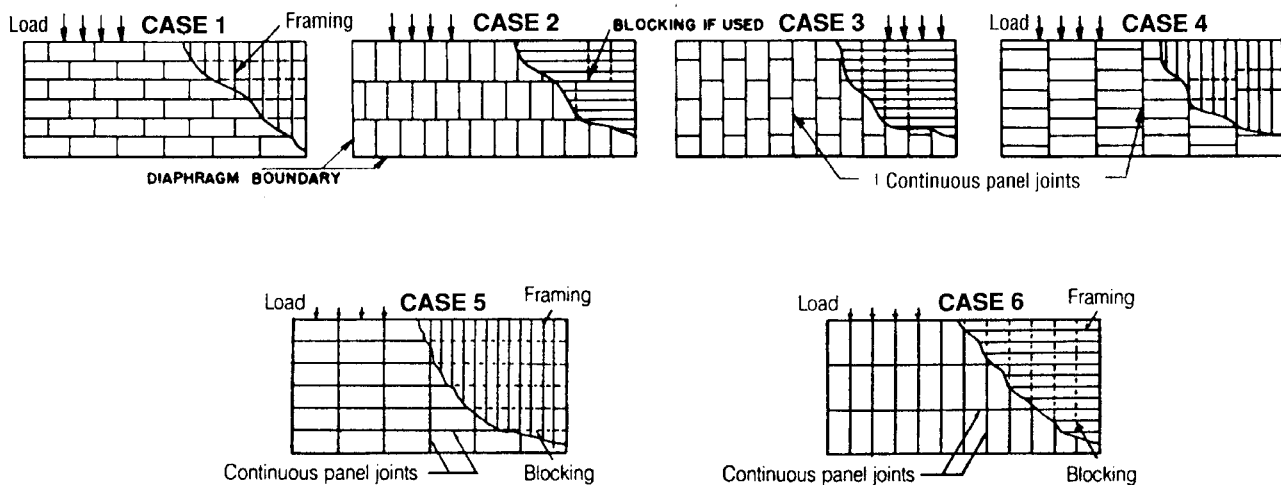

NOTE: Framing orientation in either direction for diaphragms is permitted provided sheathing is properly designed for vertical loading.

**TABLE 12**  
**ALLOWABLE SHEAR<sup>1</sup> FOR WIND OR SEISMIC LOADING (POUNDS PER FOOT) FOR**  
**WOOD STRUCTURAL PANEL SHEAR WALLS WITH FRAMING OF**  
**DOUGLAS-FIR, LARCH OR SOUTHERN PINE<sup>2</sup> FOR**  
**5/16" THICK STRUCTURAL I SHEATHING<sup>3, 4, 13, 15, 16</sup>**

Nominal Nail <sup>5</sup> Diameter (in inches) or Staple <sup>6</sup> Gage	Minimum Nominal Fastener Length <sup>7</sup> (In inches)		Allowable Wall Shear Values			
	Panels Applied Direct to Framing	Panels Applied Over 1/2" or 5/8" Gypsum Sheathing	Fastener Spacing at Panel Edges <sup>8</sup> (In inches)			
			6	4	3	2 <sup>9</sup>
0.113 smooth or deformed	1 5/8 or 2 or 2 3/8	-	200	300	390	510
0.131 smooth or deformed	2 1/2	2 1/2				
0.120 smooth	3	-	170	250	335	430
0.120 smooth	-	3				
0.099 smooth or deformed	2 1/4	-	155	235	310	400
0.113 smooth or deformed	-	2 3/8	150	225	300	385
0.092 smooth	2 1/4	-	135	205	275	350
0.113 smooth or deformed	-	2	120	175	235	300
0.099 smooth or deformed	-	2 1/4				
0.092 smooth	-	2 1/4	105	155	205	265
14 Gage	3 or 2 1/2 2 1/4 or 2	-	200	300	390	515
15 Gage	2 1/2 2 1/4 2 or 1 3/4					
16 Gage	2 1 3/4 or 1 1/2	-	165	245	325	415
14 Gage	-	3 or 2 1/2 2 1/4 or 2	180	270	360	455
15 Gage	-	2 1/2 2 1/4 or 2	155	230	305	390
16 Gage	-	2	125	185	245	315

See pages 27 and 28 for footnote explanations and typical panel layouts.

**TABLE 13**  
**ALLOWABLE SHEAR<sup>1</sup> FOR WIND OR SEISMIC LOADING (POUNDS PER FOOT) FOR**  
**WOOD STRUCTURAL PANEL SHEAR WALLS WITH FRAMING OF**  
**DOUGLAS-FIR, LARCH OR SOUTHERN PINE<sup>2</sup> FOR**  
**3/8" THICK STRUCTURAL I SHEATHING<sup>3, 4, 13, 15, 16</sup>**

Nominal Nail <sup>5</sup> Diameter (in inches) or Staple <sup>6</sup> Gage	Minimum Nominal Fastener Length <sup>7</sup> (In inches)		Allowable Wall Shear Values			
	Panels Applied Direct to Framing	Panels Applied Over 1/2" or 5/8" Gypsum Sheathing	Fastener Spacing at Panel Edges <sup>8</sup> (In inches)			
			6	4	3	2 <sup>9</sup>
0.131 smooth or deformed	1 7/8 or 2 1/2	-	230	360	460	610
0.148 smooth <sup>12</sup>	3					
0.148 smooth <sup>12</sup>	-	2 5/8	285	425	570	725
		3				
0.131 smooth or deformed	-	2 1/2	220 <sup>11</sup>	325 <sup>11</sup>	435 <sup>11</sup>	555 <sup>11</sup>
0.120 smooth	3	3	200	305	405	515
0.113 smooth or deformed	2 3/8 or 2	2 3/8	180	270	365	465
	-	2	135	200	270	340
0.099 smooth or deformed	2 1/4	2 1/4	145	220	290	370
0.092 smooth	2 1/4	2 1/4	130	190	255	325
14 Gage	3 2 1/2 2 1/4 or 2	-	225	340	455	580
	2 1/2 2 1/4 2 or 1 3/4					
15 Gage	2 1 3/4 or 1 1/2	-	155	235	315	400
14 Gage	-	3 2 1/2 2 1/4 or 2	220	340	450	575
		2 1/2 2 1/4 or 2				
15 Gage	-	2	195	290	385	490
16 Gage	-	2	155	235	310	400

See pages 27 and 28 for footnote explanations and typical panel layouts.

**TABLE 14**  
**ALLOWABLE SHEAR<sup>1</sup> FOR WIND OR SEISMIC LOADING (POUNDS PER FOOT) FOR**  
**WOOD STRUCTURAL PANEL SHEAR WALLS WITH FRAMING OF**  
**DOUGLAS-FIR, LARCH OR SOUTHERN PINE<sup>2</sup> FOR**  
**7/16" THICK STRUCTURAL I SHEATHING<sup>3, 4, 13, 15, 16</sup>**

Nominal Nail <sup>5</sup> Diameter (In Inches) or Staple <sup>6</sup> Gage	Minimum Nominal Fastener Length <sup>7</sup> (In inches)		Allowable Wall Shear Values			
	Panels Applied Direct to Framing	Panels Applied Over ½" or ⅝" Gypsum Sheathing	Fastener Spacing at Panel Edges <sup>8</sup> (In inches)			
			6	4	3	2 <sup>9</sup>
0.148 smooth <sup>12</sup>	-	2¾ or 3	280	430	550	730
0.131 smooth or deformed	2 or 2½	-	260 <sup>11</sup>	390 <sup>11</sup>	520 <sup>11</sup>	665 <sup>11</sup>
0.120 smooth	3	-	220	335	445	565
	-	3	200	305	405	515
0.113 smooth or deformed	2 or 2⅜	-	200	300	400	510
	-	2⅜	180	275	365	465
		2	125	185	245	315
0.099 smooth or deformed	2¼	-	160	240	320	405
	-	2¼	145	225	285	380
0.092 smooth	2¼	-	140	210	280	360
	-	2¼	130	190	255	325
14 Gage	3 2½ 2¼ or 2	-	250	375	500	635
15 Gage	2½ 2¼ 2 or 1¾	-	210	320	425	540
16 Gage	2 1¾ or 1½	-	170	260	345	440
14 Gage	-	3 2½ or 2¼	225	340	450	575
15 Gage	-	2½ or 2¼	195	290	385	490
16 Gage <sup>14</sup>	-	2	155	235	310	400

See pages 27 and 28 for footnote explanations and typical panel layouts.

**TABLE 15**  
**ALLOWABLE SHEAR <sup>1</sup> FOR WIND OR SEISMIC LOADING (POUNDS PER FOOT) FOR**  
**WOOD STRUCTURAL PANEL SHEAR WALLS WITH FRAMING OF**  
**DOUGLAS-FIR, LARCH OR SOUTHERN PINE <sup>2</sup> FOR**  
**15/32" THICK STRUCTURAL I SHEATHING <sup>3, 4, 13, 15, 16</sup>**

Nominal Nail <sup>5</sup> Diameter (in inches) or Staple <sup>5</sup> Gage	Minimum Nominal Fastener Length <sup>7</sup> (In inches)		Allowable Wall Shear Values			
	Panels Applied Direct to Framing	Panels Applied Over $\frac{1}{2}$ " or $\frac{5}{8}$ " Gypsum Sheathing	Fastener Spacing at Panel Edges <sup>8</sup> (In inches)			
			6	4	3	2 <sup>9</sup>
0.148 smooth <sup>12</sup>	$2\frac{1}{8}$ or 3	-	340	510	665	870
0.148 smooth <sup>12</sup>	-	$2\frac{3}{4}$ or 3	285	425	570	725
0.131 smooth or deformed	2 or $2\frac{1}{2}$	-				
0.131 smooth or deformed	-	$2\frac{1}{2}$	225	325	445	570
0.120 smooth	3	-	240	365	485	620
	-	3	200	305	405	515
0.113 smooth or deformed	2 or $2\frac{3}{8}$	-	220	325	435	555
0.113 smooth or deformed	-	$2\frac{3}{8}$	180	270	365	465
	-	2	130	200	265	335
0.099 smooth or deformed	$2\frac{1}{4}$	-	175	260	345	440
	-	$2\frac{1}{4}$	145	215	290	370
0.092 smooth	$2\frac{1}{4}$	-	155	230	305	390
	-	$2\frac{1}{4}$	130	190	255	325
14 Gage	3 $2\frac{1}{2}$ $2\frac{1}{4}$ or 2	-	270	405	540	690
15 Gage	$2\frac{1}{2}$ $2\frac{1}{4}$ 2 or $1\frac{3}{4}$	-	230	345	465	590
16 Gage	2 $1\frac{3}{4}$ or $1\frac{1}{2}$	-	185	280	375	475
14 Gage	-	3 $2\frac{1}{2}$ or $2\frac{1}{4}$	225	340	450	575
15 Gage	-	$2\frac{1}{2}$ or $2\frac{1}{4}$	195	290	385	490
16 Gage <sup>14</sup>	-	2	155	235	300	400

See pages 27 and 28 for footnote explanations and typical panel layouts.

**TABLE 16**  
**ALLOWABLE SHEAR<sup>1</sup> FOR WIND OR SEISMIC LOADING (POUNDS PER FOOT) FOR**  
**WOOD STRUCTURAL PANEL SHEAR WALLS WITH FRAMING OF**  
**DOUGLAS-FIR, LARCH OR SOUTHERN PINE<sup>2</sup> FOR**  
**5/16" THICK RATED SHEATHING<sup>3, 4, 10, 13, 15, 16</sup>**

Nominal Nail <sup>5</sup> Diameter (In Inches) or Staple <sup>6</sup> Gage	Minimum Nominal Fastener Length <sup>7</sup> (In inches)		Allowable Wall Shear Values			
	Panels Applied Direct to Framing	Panels Applied Over ½" or 5/8" Gypsum Sheathing	Fastener Spacing at Panel Edges <sup>8</sup> (In inches)			
			6	4	3	2 <sup>9</sup>
0.131 smooth	2½	2½	180	270	350	450
0.120 smooth	3					
0.113 smooth or deformed	1⅝ or 2 or 2¾	-				
0.099 smooth or deformed	2¼	-	140	210	280	360
0.092 smooth	2¼		125	185	245	315
0.120 smooth	-	3	150	225	305	385
0.113 smooth or deformed	-	2¾	135	205	270	345
		2	90	135	180	230
0.099 smooth or deformed	-	2¼	105	160	215	270
0.092 smooth	-	2¼	95	140	185	240
14 Gage	3 2½ 2¼ or 2	-	180	270	350	450
	2½ 2¼ 2 or 1¾	-				
15 Gage	2 1¾ or 1½	-	145	220	295	375
14 Gage	-	3 2½ 2¼ or 2	160	240	320	410
		2½ 2¼ or 2	140	205	275	350
15 Gage	-	2	110	165	220	285

See pages 27 and 28 for footnote explanations and typical panel layouts.

**TABLE 17**  
**ALLOWABLE SHEAR <sup>1</sup> FOR WIND OR SEISMIC LOADING (POUNDS PER FOOT) FOR**  
**WOOD STRUCTURAL PANEL SHEAR WALLS WITH FRAMING OF**  
**DOUGLAS-FIR, LARCH OR SOUTHERN PINE <sup>2</sup> FOR**  
**3/8" THICK RATED SHEATHING <sup>3, 4, 10, 13, 15, 16</sup>**

Nominal Nail <sup>5</sup> Diameter (In Inches) or Staple <sup>6</sup> Gage	Minimum Nominal Fastener Length <sup>7</sup> (In inches)		Allowable Wall Shear Values			
	Panels Applied Direct to Framing	Panels Applied Over 1/2" or 5/8" Gypsum Sheathing	Fastener Spacing at Panel Edges <sup>8</sup> (In inches)			
			6	4	3	2 <sup>9</sup>
0.131 smooth or deformed	1 7/8 or 2 1/2	-	220 <sup>11</sup>	320 <sup>11</sup>	410 <sup>11</sup>	530 <sup>11</sup>
0.148 smooth <sup>12</sup>	3					
0.148 smooth <sup>12</sup>	-	2 5/8 or 3	255	385	510	650
0.120 smooth	3	-	180	270	365	465
	-	3	170	255	330	430
0.113 smooth or deformed	1 5/8 or 2 or 2 3/8	-	165	245	325	415
	-	2 3/8	165	245	325	415
	-	2	120	180	240	305
0.099 smooth or deformed	2 1/4	-	130	195	265	335
	-	2 1/4	120	175	230	300
0.092 smooth	2 1/4	-	115	170	230	295
	-	2 1/4	115	170	230	295
14 Gage	3 2 1/2 2 1/4 or 2	-	205	305	410	520
15 Gage	2 1/2 2 1/4 2 or 1 3/4	-	175	260	350	445
16 Gage	2 1 3/4 or 1 1/2	-	140	210	280	360
14 Gage	-	3 2 1/2 2 1/4 or 2	205	305	405	520
15 Gage	-	2 1/2 2 1/4 or 2	175	260	345	445
16 Gage	-	2	140	210	280	360

See pages 27 and 28 for footnote explanations and typical panel layouts.

**TABLE 18**  
**ALLOWABLE SHEAR <sup>1</sup> FOR WIND OR SEISMIC LOADING (POUNDS PER FOOT) FOR**  
**WOOD STRUCTURAL PANEL SHEAR WALLS WITH FRAMING OF**  
**DOUGLAS-FIR, LARCH OR SOUTHERN PINE <sup>2</sup> FOR**  
**7/16" THICK RATED SHEATHING <sup>3, 4, 10, 13, 15, 16</sup>**

Nominal Nail <sup>5</sup> Diameter (In Inches) or Staple <sup>6</sup> Gage	Minimum Nominal Fastener Length <sup>7</sup> (In inches)		Allowable Wall Shear Values			
	Panels Applied Direct to Framing	Panels Applied Over 1/2" or 5/8" Gypsum Sheathing	Fastener Spacing at Panel Edges <sup>8</sup> (In inches)			
			6	4	3	2 <sup>9</sup>
0.131 smooth or deformed	2 or 2 1/2	-	240 <sup>11</sup>	350 <sup>11</sup>	450 <sup>11</sup>	585 <sup>11</sup>
0.148 smooth <sup>12</sup>	3					
0.148 smooth <sup>12</sup>	-	2 3/4 or 3	255	385	510	650
0.120 smooth	3	-	200	300	400	510
	-	3	180	270	365	460
0.113 smooth or deformed	2 3/8 or 2	-	180	270	360	460
	-	2 3/8	165	245	325	415
		2	125	185	245	315
0.099 smooth or deformed	2 1/4	-	145	215	285	365
	-	2 1/4	130	195	260	330
0.092 smooth	2 1/4	-	125	190	255	325
	-	2 1/4	115	170	230	295
14 Gage	3 2 1/2 2 1/4 or 2	-	225	335	450	570
15 Gage	2 1/2 or 2 1/4 2 or 1 3/4	-	190	285	380	490
16 Gage	2 1 3/4 or 1 1/2	-	155	230	310	395
14 Gage	-	3 2 1/2 or 2 1/4	205	305	405	520
15 Gage	-	2 1/2 or 2 1/4	175	260	345	445
16 Gage <sup>14</sup>	-	2	140	210	280	360

See pages 27 and 28 for footnote explanations and typical panel layouts.

**TABLE 19**  
**ALLOWABLE SHEAR<sup>1</sup> FOR WIND OR SEISMIC LOADING (POUNDS PER FOOT) FOR**  
**WOOD STRUCTURAL PANEL SHEAR WALLS WITH FRAMING OF**  
**DOUGLAS-FIR, LARCH OR SOUTHERN PINE<sup>2</sup> FOR**  
**15/32" THICK RATED SHEATHING<sup>3, 4, 10, 13, 15, 16</sup>**

Nominal Nail <sup>5</sup> Diameter (In Inches) or Staple <sup>6</sup> Gage	Minimum Nominal Fastener Length <sup>7</sup> (In inches)		Allowable Wall Shear Values			
	Panels Applied Direct to Framing	Panels Applied Over 1/2" or 5/8" Gypsum Sheathing	Fastener Spacing at Panel Edges <sup>8</sup> (In inches)			
			6	4	3	2 <sup>9</sup>
0.148 smooth <sup>12</sup>	2 1/8 or 3	-	310	460	600	770
	-	2 3/4 or 3	255	385	510	650
0.131 smooth or deformed	2 or 2 1/2	-	255	385	510	650
	-	2 1/2	215	320	425	545
0.120 smooth	3	-	220	325	435	555
	-	3	180	270	365	465
0.113 smooth or deformed	2 3/8 or 2	-	195	295	390	500
	-	2 3/8	165	245	325	415
	-	2	120	150	240	305
0.099 smooth or deformed	2 1/4	-	155	235	310	395
	-	2 1/4	130	190	245	320
0.092 smooth	2 1/4	-	140	205	275	350
	-	2 1/4	120	170	220	290
14 Gage	3 2 1/2 2 1/4 or 2	-	245	365	490	620
15 Gage	2 1/2 2 1/4 2 or 1 3/4	-	210	310	415	530
16 Gage	2 1 3/4 or 1 1/2	-	170	255	335	430
14 Gage	-	3 2 1/2 or 2 1/4	205	305	405	520
15 Gage	-	2 1/2 or 2 1/4	175	260	345	445
16 Gage <sup>14</sup>	-	2	140	210	280	360

See pages 27 and 28 for footnote explanations and typical panel layouts.

**TABLE 20**  
**ALLOWABLE SHEAR<sup>1</sup> FOR WIND OR SEISMIC LOADING (POUNDS PER FOOT) FOR**  
**WOOD STRUCTURAL PANEL SHEAR WALLS WITH FRAMING OF**  
**DOUGLAS-FIR, LARCH OR SOUTHERN PINE<sup>2</sup> FOR**  
**19/32" THICK RATED SHEATHING<sup>3, 4, 10, 13, 15, 16</sup>**

Nominal Nail <sup>5</sup> Diameter (in inches) or Staple <sup>6</sup> Gage	Minimum Nominal Fastener Length <sup>7</sup> (In inches)		Allowable Wall Shear Values			
	Panels Applied Direct to Framing	Panels Applied Over 1/2" or 5/8" Gypsum Sheathing	Fastener Spacing at Panel Edges <sup>8</sup> (In inches)			
			6	4	3	2 <sup>9</sup>
0.148 smooth <sup>12</sup>	2 1/4 or 3	-	340	510	665	870
0.131 smooth or deformed	2 1/2	-	285	430	575	730
0.120 smooth	3	-	245	370	495	630
0.113 smooth or deformed	2 3/8 or 2	-	225	335	445	570
0.099 smooth or deformed	2 1/4	-	180	270	360	460
0.092 smooth	2 1/4	-	160	245	325	415
14 Gage	3 2 1/2 2 1/4 or 2	-	270	405	540	690
15 Gage	2 1/2 2 1/4 2 or 1 3/4	-	230	345	465	590
16 Gage	2 or 1 3/4	-	185	280	375	475

See page 28 for footnote explanations.

**Panel Layouts for Shear Walls Described in Tables 12 - 20**

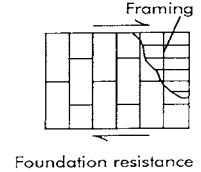
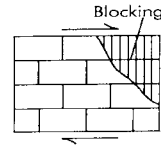
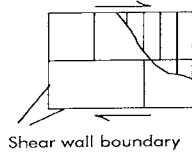
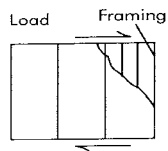

**Footnote Explanations for Shear Wall Tables 12-20**

1. Tabulated values are for short-time loading due to wind or earthquake and shall be reduced by 25 percent for normal loading based on a duration of load factor of 1.33 and a diaphragm factor of 1.3. For diaphragm deflection analysis, deflections in Appendix A, Table B or C shall be used.
2. All panel edges shall be backed by framing members. The tabulated values are for 2-inch nominal or wider framing members of Douglas Fir-Larch or Southern Pine. Allowable values for shear walls framed with wood having a specific gravity equal to or greater than 0.42 but less than 0.50 may be calculated by multiplying the values above by 0.82. For woods with specific gravity less than 0.42 multiply the values above by 0.65.
3. Panel layout: install panels either horizontally or vertically.
4. Fastener spacing intermediate: Space fasteners maximum 6 inches on center along intermediate framing members for  $\frac{3}{8}$  inch and  $\frac{7}{16}$  inch panels installed on studs spaces 24 inches on center. For other conditions and panel thicknesses, space fasteners maximum 12 inches on center.
5. Nails with "T," brad, finish or casing heads are not permitted. A deformed shank nail shall have either a helical (screw) shank or an annular (ring) shank.
6. Staples shall have a  $\frac{7}{16}$  inch minimum crown width.
7. Changes to fastener type, size or spacing shall be considered if shear wall panels are required to withstand negative pressures of high winds or where prescribed in the model code. Prescriptive fastener schedules are summarized in Tables 28 to 37.
8. Where panels are applied to both faces of a wall and fastener spacing is less than 6 inches on center on either side, panel joints shall be offset to fall on different framing members, or framing shall be 3-inch nominal or thicker and fasteners on each side shall be staggered.
9. Framing at adjoining panel edges shall be 3-inch nominal or wider, and fasteners shall be staggered where fasteners are spaced 2 inches on center.
10. C-D, C-C Exterior Sheathing and other panel grades covered in PS 1 or PS 2.
11. The values for  $\frac{3}{8}$  inch and  $\frac{7}{16}$  inch panels applied directly to framing may be increased to values shown for  $\frac{15}{32}$  inch thick panels of the same panel grade, provided studs are spaces a maximum of 16 inches on center or panels are applied with long dimension across studs.
12. Framing at adjacent panel edges shall be 3 inch nominal or wider and fasteners shall be staggered where nails with shank diameters of 0.148" or greater and penetration of  $1\frac{5}{8}$  inches or greater are placed 3 inches on center or closer.
13. In addition to requirements presented above for fastening of shear walls all other requirements of the applicable model code (such as, but not limited to, conditions of use and modification of design values for certain Seismic Design Categories) pertaining to shear wall design and construction shall be met.
14. Two-inch-long staples have insufficient penetration when wood structural sheathing is applied over  $\frac{5}{8}$  inch thick gypsum sheathing and shall only be used if wood structural sheathing is applied directly to framing or over gypsum sheathing having a maximum thickness of  $\frac{1}{2}$  inch.
15. Where allowable shear values exceed 350 pounds per foot, foundation sill plates and all framing members receiving edge nailing from abutting panels shall not be less than a single 3 inch nominal member. Nails shall be staggered.
16. In structures assigned to Seismic Design Category D, E, or F in areas using the IBC, where shear design values exceed 490 plf (LRFD) or 350 plf (ASD) all framing members receiving edge nailing from abutting panels shall not be less than a single 3-inch nominal member. Plywood joint and sill plate nailing shall be staggered in all cases.

**TABLE 21**  
**ALLOWABLE SHEAR<sup>1</sup> FOR WIND OR SEISMIC LOADING (POUNDS PER FOOT) FOR**  
**5/16" and 3/8" PLYWOOD PANEL SIDING SHEAR WALLS WITH FRAMING OF**  
**DOUGLAS-FIR, LARCH OR SOUTHERN PINE<sup>1, 2, 7, 8, 9</sup>**

Nominal Nail Diameter <sup>3</sup> (Inches)	Minimum Nominal Fastener Length <sup>4</sup> (In inches)		Allowable Wall Shear Values			
	Panels Applied Direct to Framing	Panels Applied Over 1/2" or 5/8" Gypsum Sheathing	Fastener Spacing at Panel Edges <sup>10</sup> (Inches)			
			6	4	3	2 <sup>5</sup>
5/16" Thick Panel Siding						
0.099" casing nail ( 6d casing)	2	-	140	210	275	360
0.099" finish nail						
0.099" smooth						
0.113" casing nail ( 8d casing)	-	2 1/2	140	210	275	360
0.113" finish nail						
0.113" smooth						
3/8" Thick Panel Siding						
0.113" casing nail ( 8d casing)	1 5/8 <sup>6</sup>	-	130	200	260	340
0.113" finish nail						
0.113" smooth						
0.128" casing nail ( 10d casing)	-	2 3/8	160	240	310	410
0.128" finish nail						
0.128" smooth						

See page 36 for typical panel layouts.

<sup>1</sup>All panel edges backed with 2-inch nominal or wider framing. Panels are oriented either horizontally or vertically. Space fasteners maximum 6 inches o.c. along intermediate framing members for 3/8" panels installed with face grain parallel to studs spaced 24" o.c., and 12 inches o.c. for other conditions and panel thicknesses. These values are for short-time loading due to wind or earthquake and must be reduced by 25 percent for normal loading.

<sup>2</sup>The tabulated values are for fasteners installed in Douglas Fir-Larch or Southern Pine (Group II species). Species groupings are described in Table A, Appendix A. To determine the allowable values for Groups III and IV species, as shown in the Appendix, multiply the value tabulated for the Group II species by the following factors: I-1.00, III-0.82, IV-0.65.

<sup>3</sup>Steel wire fasteners exposed to the weather in service shall be zinc coated by a hot-dip, mechanical deposition or electro-deposition galvanizing process. Fasteners manufactured from aluminum 5056 or 6061 alloy wire or other nonferrous alloys do not require protective coatings. For construction to SBCCI SSTD 10, fasteners exposed directly to the weather or subject to salt corrosion in coastal areas, as determined by the building official, shall be stainless steel or hot dip galvanized after fabrication to 1 oz. per sq ft. For construction to UBC Appendix Section 2337, fasteners in exposed locations or in areas otherwise subject to corrosion shall have a corrosion resistance equal to or greater than a hot-dipped galvanized coating of 1.5 ounces of zinc per sq ft of surface area.

<sup>4</sup>The tabulated penetrations are for fasteners installed in species with a specific gravity of 0.50 or greater. Penetration shall be increased to 13 diameters for species with a specific gravity of 0.42 to less than 0.50 and 14 diameters for species with a specific gravity less than 0.42.

<sup>5</sup>Framing at adjoining panel edges shall be 3" nominal or wider and nails shall be staggered where nails are spaced 2" o.c.

<sup>6</sup>The value for 3/8 inch thick plywood applied direct to framing may be increased by 20 percent, provided studs are spaced a maximum of 16 inches on center or plywood is applied with face grain across studs, or if the plywood thickness is increased to 1/2 inch or more.

<sup>7</sup>Panel thickness is measured at fastener locations.

<sup>8</sup>Changes to fastener type, size or spacing shall be considered if shear walls are required to withstand negative pressures of high winds. See Tables 38 through 44.

<sup>9</sup>In addition to requirements presented above for fastening of shear walls all other requirements of the applicable model code (such as, but not limited to, conditions of use and modification of design values for certain Seismic Design Categories) pertaining to shear wall design and construction shall be met.

<sup>10</sup>Where panels are applied to both faces of a wall and fastener spacing is less than 6 inches on center on either side, panel joints shall be offset to fall on different framing members, or framing shall be 3-inch nominal or thicker and fasteners on each side shall be staggered.

**TABLE 22**  
**ALLOWABLE SHEAR FOR WIND OR SEISMIC FORCES IN POUNDS PER FOOT FOR SHEAR WALLS OF WALL SHEATHING, GYPSUM LATH-PLASTER, WALLBOARD AND EXTERIOR PLASTER ATTACHED TO WOOD-FRAMED WALL ASSEMBLIES** <sup>1, 2, 3, 12</sup>

Description Attached Material	Thickness of Material	Wall Construction	Spacing <sup>4</sup> Specifications (Inches)		Shear Value <sup>5</sup>	Fastener Specifications	
			Edges	Intermediate		Min. Leg Length <sup>6</sup> (Inches)	Fastener Style <sup>7,8,9,10</sup>
Fiberboard Sheathing	1/2"	Blocked	3	6	50	1 1/2	0.120" Galv. Roofing Nail
					50		14 Ga. Galv. Staple
					50	1 1/2	15 Ga. Galv. Staple
	25/32"	Blocked	3	6	60	1 3/4	0.120" Galv. Roofing Nail
					60		14 Ga. Galv. Staple
					60	1 3/4	15 Ga. Galv. Staple
Gypsum <sup>11</sup> Lath	3/8" lath & 1/2" Plaster	Unblocked	5" On Center		100	1 1/8	0.091" Nail, min 19/64" head
						1 1/4	16 Ga. Galv. Staple
Gypsum Sheathing Board	1/2" x 2' x 8'	Unblocked	4" On Center		75	1 3/4	16 Ga. Galv. Staple
	1/2" x 2' x 8'	Blocked			175		0.120" Nail, min 3/8" head
Gypsum Wallboard	1/2"	Unlocked	7" On Center		100	1 5/8	5d Cooler Nail
			4" On Center		125		0.086" Nail
		Blocked	7" On Center		125	1 1/2	0.120" Nail, min 3/8" head
			4" On Center		150		16 Gage Staple
	5/8"	Blocked	4" On Center		175	1 7/8	6d Cooler Nail
						1 3/4	0.120" Nail, min 3/8" head
						1 5/8	16 Ga. Galv. Staple
						1 7/8	6d Cooler Nail
		Blocked two-ply	Base ply - 9" - Center		250	1 7/8	0.092" Nail
						1 3/4	0.120" Nail, min 3/8" head
						1 5/8	16 Ga. Galv. Staple
						2 3/8	8d Cooler Nail
Face ply - 7" - Center		250	2 3/8	0.113" Nail			
			2 1/4	0.120" Nail, min 3/8" head			
Self-furred <sup>11</sup> Woven Wire Lath	2" x 4" studs spaced 24" maximum on center. Lath stapled 6" o.c. to all studs, top and bottom plate. Wall finished with 7/8" thick exterior plaster.				180	7/8	16 Ga. Galv. Staple

<sup>1</sup>These vertical shear walls shall not be used to resist loads imposed by masonry or concrete construction. Values are for short-time loading due to wind or seismic loading. Values shall be reduced 25 percent for normal loading. Values for lath, plaster, and gypsum board subject to seismic forces shall be reduced 50 percent for buildings assigned to Seismic Design Category D (UBC Zones 3 and 4). Lath, plaster, and gypsum board shall not be used to resist seismic forces in structures assigned to Seismic Design Categories E and F. Values for fiberboard sheathing subject to seismic forces shall be reduced 50 percent in buildings assigned to Seismic Performance Category C. Fiberboard sheathing shall not be used to resist seismic forces in structures assigned to Seismic Performance Category D, E, and F. In addition to requirements presented above for fastening of shear walls, all other requirements of the applicable model code pertaining to shear wall design and construction shall be met.

<sup>2</sup>Shear values are based on a maximum framing spacing of 16 inches on center.

<sup>3</sup>Shear values shall be doubled where identical materials are applied to both sides of the wall.

<sup>4</sup>Applied to nailing at all studs, top and bottom plates and blocking.

<sup>5</sup>The tabulated values are for fasteners installed in Douglas fir-larch or Southern Pine (Group II species). To determine the allowable values for Groups III and IV species, as shown in the Appendix, multiply the value tabulated for the Group II species by the following factors: I-1.00, III-0.82, IV-0.65.

<sup>6</sup>The tabulated penetrations are for fasteners installed in Group I or II species. Penetration shall be increased to 13 diameters for Group III and 14 diameters for Group IV species.

<sup>7</sup>Material attached to redwood and Group III species of wood with a specific gravity of 0.42 to less than 0.50, add minimum of 3/8 inch to fastener leg lengths.

<sup>8</sup>Steel wire fasteners exposed to the weather in service shall be zinc coated by a hot-dip, mechanical deposition or electro-deposition galvanizing process. Fasteners manufactured from aluminum 5056 or 6061 alloy wire or other nonferrous alloys do not require protective coatings. For construction to SBCCI SSTD 10, fasteners exposed directly to the weather or subject to salt corrosion in coastal areas, as determined by the building official, shall be stainless steel or hot dip galvanized after fabrication to 1 oz. per sq ft. For construction to UBC Appendix Section 2337, fasteners in exposed locations or in areas otherwise subject to corrosion shall have a corrosion resistance equal to or greater than a hot-dipped galvanized coating of 1.5 ounces of zinc per sq ft of surface area.

<sup>9</sup>Staples shall have a minimum crown width of 7/16 inch, measured outside the legs.

<sup>10</sup>Nails with "T", brad, finish or casing heads are not permitted.

<sup>11</sup>Staples for the attachment of gypsum lath and woven-wire lath shall have a minimum crown width of 3/4 inch, measured outside the legs.

<sup>12</sup>In addition to requirements presented above for fastening of shear walls all other requirements of the applicable model code (such as, but not limited to, conditions of use and modification of design values for certain Seismic Design Categories) pertaining to shear wall design and construction shall be met.

**TABLE 23  
WALL FRAMING<sup>1</sup>**

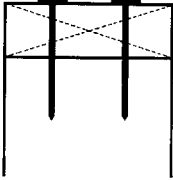
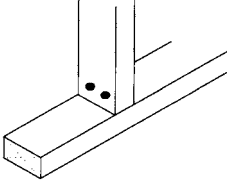
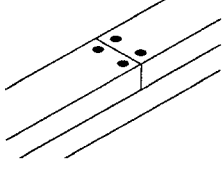
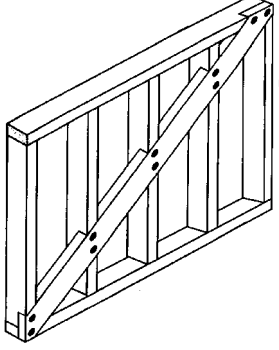
Connection <sup>2</sup> (Nail size and position exaggerated for illustrative purposes.)	Fastener Minimum nominal length in inches x Minimum nominal nail diameter in inches	Quantity per connection, Or Spacing between fasteners (inches on-center) <sup>4</sup>
Top or sole plate to stud (face nail) 	3 1/2" x 0.162" nail (16d common) <sup>3</sup>	2
	3" x 0.148" nail (10d common)	3
	3 1/4" x 0.131" nail	
	3" x 0.131" nail	
	3 1/4" x 0.120" nail	4
	3" x 0.120" nail	
Stud to top or sole plate (toe nail) 	2 1/2" x 0.131" nail (8d common) <sup>3</sup>	4
	3 1/2" x 0.162" nail (16d common)	3
	3" x 0.148" nail (10d common)	4
	3 1/4" x 0.131" nail	
	3" x 0.131" nail	
	3 1/4" x 0.120" nail	
	3" x 0.120" nail	5
	2 3/8" x 0.113" nail	
	2" x 0.113" nail	
	2 1/4" x 0.105" nail	
2 1/4" x 0.099" nail		
Cap/top plate laps and intersections 	3 1/2" x 0.162" nail (16d common) <sup>3</sup>	2 each side of lap
	3" x 0.148" nail	3 each side of lap
	3 1/4" x 0.131" nail	
	3" x 0.131" nail	
	3 1/4" x 0.120" nail	
	3" x 0.120" nail	
Diagonal bracing 	2 1/2" x 0.131" nail (8d common) <sup>3</sup>	2
	3 1/2" x 0.162" nail (16d common)	
	3" x 0.148" nail (10d common)	
	3 1/4" x 0.131" nail	
	3" x 0.131" nail	3
	3 1/4" x 0.120" nail	
	3" x 0.120" nail	
	2 3/8" x 0.113" nail	4
	2" x 0.113" nail	
	2 1/4" x 0.105" nail	
2 1/4" x 0.099" nail		

See page 36 for footnotes.

Table 23 continued on next page.

**TABLE 23, continued**  
**WALL FRAMING<sup>1</sup>**

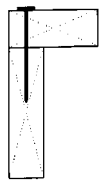
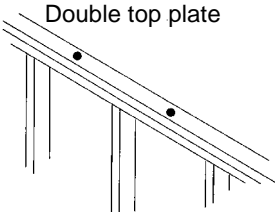
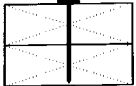
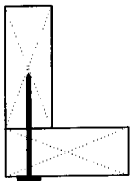
Connection <sup>2</sup> (Nail size and position exaggerated for illustrative purposes.)	Fastener Minimum nominal length in inches x Minimum nominal nail diameter in inches	Quantity per connection, Or Spacing between fasteners (inches on-center) <sup>4</sup>
Sole plate to joist or blocking @ braced panels 	3½" x 0.135" nail (16d box) <sup>3</sup>	3 per 16" space
	3½" x 0.162" nail (16d common)	2 per 16" space
	3" x 0.148" nail (10d common)	3 per 16" space
	¾" x 0.131" nail	
	3" x 0.131" nail	4 per 16" space
	¾" x 0.120" nail	
	3" x 0.120" nail	
Sole plate to joist or blocking 	3½" x 0.162" nail (16d common) <sup>3</sup>	16" o.c.
	3" x 0.148" nail (10d common)	8" o.c.
	¾" x 0.131" nail	
	3" x 0.131" nail	
	¾" x 0.120" nail	
	3" x 0.120" nail	
Double top plate 	3" x 0.148" nail (10d common) <sup>3</sup>	16" o.c.
	3½" x 0.162" nail (16d common)	12" o.c.
	¾" x 0.131" nail	
	3" x 0.131"	
	¾" x 0.120" nail	
	3" x 0.120" nail	
Double studs 	3" x 0.148" nail (10d common) <sup>3</sup>	12" o.c.
	3½" x 0.162" nail (16d common)	8" o.c.
	¾" x 0.131" nail	
	3" x 0.131" nail	
	¾" x 0.120" nail	
	3 x 0.120" nail	
Corner studs 	3½" x 0.162" nail (16d common) <sup>3</sup>	24" o.c.
	3" x 0.148" nail (10d common)	16" o.c.
	¾" x 0.131" nail	
	3" x 0.131" nail	
	¾" x 0.120" nail	12" o.c.
	3" x 0.120" nail	

See page 36 for footnotes.

**TABLE 24  
CEILING AND ROOF FRAMING <sup>1</sup>**

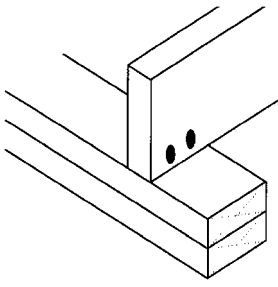
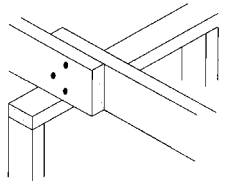
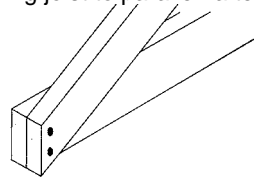
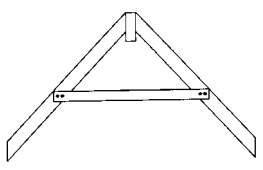
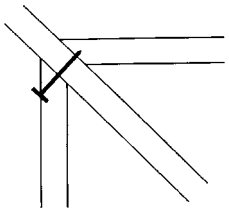
Connection <sup>2</sup> (Nail size and position exaggerated for illustrative purposes.)		Fastener Minimum nominal length in inches x Minimum nominal nail diameter in inches	Quantity per connection <sup>4</sup>		
Ceiling joist to plate  		3½" x 0.162" nail (16d common) <sup>3</sup>	3		
		3" x 0.148" nail (10d common)	4		
		¾" x 0.131" nail	5		
		3" x 0.131" nail			
		¾" x 0.120" nail			
		3" x 0.120" nail	6		
		Ceiling joists, laps over partitions  		3½" x 0.162" nail (16d common) <sup>3</sup>	3
3" x 0.148" nail (10d common)	4				
Ceiling joist to parallel rafter  		¾" x 0.131" nail			
		3" x 0.131" nail			
Collar tie to rafter  		¾" x 0.120" nail	4		
		3" x 0.120" nail			
		3" x 0.148" nail (10d common) <sup>3</sup>			
		Jack rafter to hip, toe-nailed  		¾" x 0.131" nail	3
				3" x 0.148" nail (10d common) <sup>3</sup>	
¾" x 0.131" nail	4				
3" x 0.131" nail					
¾" x 0.120" nail					
3" x 0.120" nail					

See page 36 for footnotes.

Table 24 continued on next page.

**TABLE 24, continued  
CEILING AND ROOF FRAMING <sup>1</sup>**

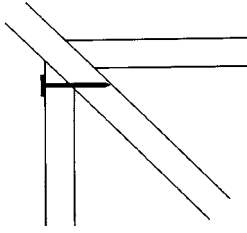
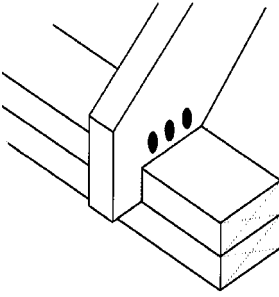
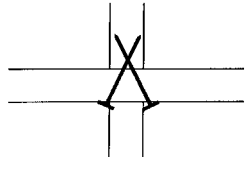
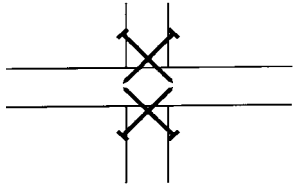
Connection <sup>2</sup> (Nail size and position exaggerated for illustrative purposes.)	Fastener Minimum nominal length in inches x Minimum nominal nail diameter in inches	Quantity per connection <sup>4</sup>
<p>Jack rafter to hip, face nailed</p> 	3½" x 0.162" nail (16d common) <sup>3</sup>	2
	3" x 0.148" nail (10d common)	3
	¾" x 0.131" nail	
	3" x 0.131" nail	
	¾" x 0.120" nail	4
	3" x 0.120" nail	
<p>Roof rafter to plate (toe-nailed)</p> 	2½" x 0.131" nail (8d common) <sup>3</sup>	3
	3½" x 0.162" nail (16d common)	
	3" x 0.148" nail (10d common)	
	¾" x 0.131" nail	
	3" x 0.131" nail	
	¾" x 0.120" nail	4
	3" x 0.120" nail	
	2⅝" x 0.113" nail	5
	2" x 0.113" nail	
	2¼" x 0.105" nail	
2¼" x 0.099" nail	6	
<p>Roof rafter to 2-by ridge beam, face nailed</p>  <p>(Only the attachment of the top rafter is illustrated.)</p>	3½" x 0.162" nail (16d common) <sup>3</sup>	2
	3" x 0.148" nail (10d common)	3
	¾" x 0.131" nail	
	3" x 0.131" nail	
	¾" x 0.120" nail	4
	3" x 0.120" nail	
<p>Roof rafter to 2-by ridge beam, toe-nailed</p> 	3½" x 0.162" nail (16d common) <sup>3</sup>	2
	3" x 0.148" nail (10d common)	3
	¾" x 0.131" nail	
	3" x 0.131" nail	
	¾" x 0.120" nail	4
	3" x 0.120" nail	

See page 36 for footnotes.

**TABLE 25  
FLOOR FRAMING <sup>1</sup>**

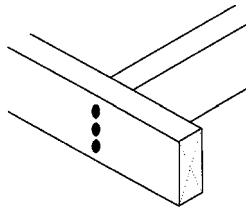
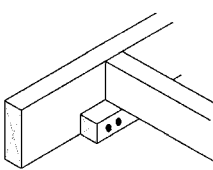
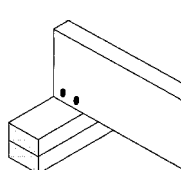
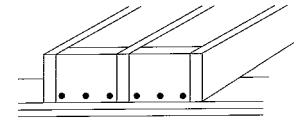
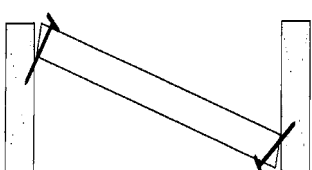
Connection <sup>2</sup> (Nail size and position exaggerated for illustrative purposes.)		Fastener Minimum nominal length in inches x Minimum nominal nail diameter in inches	Quantity per connection or maximum spacing <sup>4</sup>	
<p>Joist to band joist</p> 		3½" x 0.162" nail ( 16d common) <sup>3</sup>	3	
		3" x 0.148" nail ( 10d common)	5	
		¾" x 0.131" nail		
		3" x 0.131" nail		
		¾" x 0.120" nail	6	
		3" x 0.120" nail		
<p>Ledger strip</p> 		3½" x 0.162" nail ( 16d common) <sup>3</sup>	3	
		3" x 0.148" nail ( 10d common)	4	
		¾" x 0.131" nail		
		3" x 0.131" nail		
		¾" x 0.120" nail	4	
		3" x 0.120" nail		
<p>Joist to sill or girder (toe-nailed)</p> 	<p>Blocking between joist or rafter to top plate (toe-nailed)</p> 	2½" x 0.131" nail ( 8d common) <sup>3</sup>	3	
				3" x 0.148" nail ( 10d common)
				¾" x 0.131" nail
			3" x 0.131" nail	4
			¾" x 0.120" nail	
			3" x 0.120" nail	
<p>Bridging to joist (listed number of fasteners at each end)</p> 		2½" x 0.131" nail ( 8d common) <sup>3</sup>	2	
		¾" x 0.120"	3	
		3" x 0.120" nail		
		⅝" x 0.113" nail		
		2" x 0.113" nail ( 6d common)	4	
		2¼" x 0.105" nail	3	
		2¼" x 0.099" nail	4	

See page 36 for footnotes.

Table 25 continued on next page.

**TABLE 25, continued**  
**FLOOR FRAMING<sup>1</sup>**

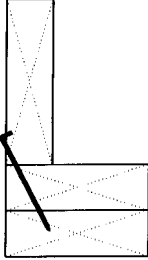
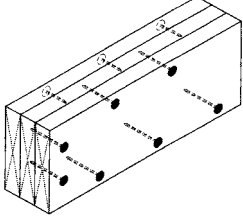
Connection <sup>2</sup> (Nail size and position exaggerated for illustrative purposes.)	Fastener Minimum nominal length in inches x Minimum nominal nail diameter in inches		Quantity per connection or maximum spacing <sup>4</sup>
	2½" x 0.113" nail (8d box) <sup>3</sup>		6" o.c.
	3½" x 0.162" nail (16d common)		8" o.c.
	3" x 0.148" nail (10d common)		6" o.c.
	¾" x 0.131" nail		
	3" x 0.131" nail		
	¾" x 0.120" nail		
	3" x 0.120" nail		4" o.c.
	2⅜" x 0.113" nail		6" o.c.
	2" x 0.113" nail (6d common)		3" o.c.
	2¼" x 0.105" nail		
	2¼" x 0.099" nail		
Connection <sup>2</sup> (Nail size and position exaggerated for illustrative purposes.)	Fastener Minimum nominal length in inches x Minimum nominal nail diameter in inches	Spacing of fasteners along the top and bottom of beam, staggered on each side of each layer	Number of fasteners at each end and splice for each layer
	4" x 0.192" nail (20d common) <sup>3</sup>	32" o.c.	2
	3½" x 0.162" nail (16d common) 3" x 0.148" nail (10d common) ¾" x 0.131" nail 3" x 0.131" nail	24" o.c.	3
	¾" x 0.120" nail 3" x 0.120" nail	16" o.c.	3
	2½" x 0.131" nail (8d common)	16" o.c.	4

**Footnotes for Tables 23 - 25**

<sup>1</sup>This fastening schedule applies to framing members having an actual thickness of 1½" (nominal "2-by" lumber).

<sup>2</sup>Fastenings listed above may also be used for other connections that are not listed but that have the same configuration and the same code requirement for fastener quantity/spacing and fastener size (pennyweight and style, e.g., 8d common, "8-penny common nail").

<sup>3</sup>This fastener, in the quantity or spacing shown in the rightmost column, comprises the most stringent fastening of the connection listed in the International, National, International One and Two Family Dwelling, International Residential, Standard or Uniform Building Codes.

<sup>4</sup>Fastening schedule only applies to buildings of conventional wood frame construction where wind or seismic analysis is not required by the applicable code. In areas where wind or seismic analysis is required, required fastening shall be determined by structural analysis. Following are conditions for which codes require structural analysis:

- *International Building Code* - buildings located in areas where design wind speeds exceed 100 mph (161 km/hr) (3-second gust) or 110 mph (177 km/hr) (3-second gust) in Exposure Categories A or B. Structural analysis is also required on buildings assigned to seismic design categories B, C, D or E, with exception of detached Group R-3 dwellings assigned to seismic design category B and some detached R-3 dwellings assigned to seismic design category C.

- *International Residential Code* - buildings located in areas where the design wind speed equals or exceeds 110 mph (177.1 km/h) (3 second gust) or assigned to seismic design categories C, D1 and D2 (with detached one- and two-family dwellings in category C being exempt).

- *BOCA National Building Code* - buildings in any location.

- *Standard Building Code* - buildings located in areas where design wind speeds prescribed exceed 80 mph or which do not qualify for one of the exceptions outlined in Section 1607.1 of the code.

- *SBCCI Standard SSTD 10* - this fastening schedule equivalent to that contained in Appendix E of the standard. However, note that specific provisions in the standard may supercede or supplement this schedule.

- *Uniform Building Code* - buildings located in areas where the design wind speeds prescribed are 80 mph or higher. Sections 2320.4 and 2320.5 of the code for additional requirements in various seismic zones.

- *International One and Two Family Dwelling Code* - buildings other than one story buildings in height in exposure classification A/B unless over 50 feet in height, or with unusual construction or geometric shapes, with overhanging eave projections greater than 24 inches, or located in special wind regions or localities.

**TABLE 26  
SUMMARY OF USE OF FASTENERS FOR FRAMING<sup>1</sup>**

Connection <sup>2,3</sup>	Number, or Spacing, of Fasteners Required per Connection										
	Nail lengths are minimum, nominal lengths, in inches Nail shank diameters are minimum, nominal diameters, in inches.										
	3½ x 0.162	3 x 0.148	3¼ x 0.131	3 x 0.131	2½ x 0.131	3¼ x 0.120	3 x 0.120	2¾ x 0.113	2 x 0.113	2¼ x 0.105	2¼ x 0.099
Floor Framing											
Joist to band joist	3	5	5	5	N/A	6	6	N/A	N/A	N/A	N/A
Ledger strip	3	4	4	4	6	4	4	N/A	N/A	N/A	N/A
Joist to sill or girder	3	3	3	3	3	4	4	N/A	N/A	N/A	N/A
Blocking between joist or rafter to top plate	3	3	3	4	3	4	4	N/A	N/A	N/A	N/A
Bridging to joist	N/A	N/A	N/A	N/A	2	3	3	3	4	3	4
Rim joist to top plate	8" o.c.	6" o.c.	6" o.c.	6" o.c.	6" o.c.	6" o.c.	4" o.c.	6" o.c.	3" o.c.	3" o.c.	3" o.c.
Built-up Girders & Beams - Spacing along edges, - # at ends & splices	24" o.c., 3	24" o.c., 3	24" o.c., 3	24" o.c., 3	16" o.c., 4	16" o.c., 3	16" o.c., 3	N/A	N/A	N/A	N/A
Ceiling and Roof Framing											
Ceiling joist to plate	3	4	5	5	5	5	5	6	N/A	N/A	N/A
Ceiling joists, laps over partitions	3	4	4	4	6	4	4	N/A	N/A	N/A	N/A
Ceiling joist to parallel rafter	3	4	4	4	6	4	4	N/A	N/A	N/A	N/A
Collar tie to rafter	3	3	4	4	5	4	4	N/A	N/A	N/A	N/A
Jack rafter to hip, toe-nailed	3	3	4	4	5	4	4	N/A	N/A	N/A	N/A
Jack rafter to hip, face nailed	2	3	3	3	3	4	4	N/A	N/A	N/A	N/A
Roof rafter to plate	3	3	3	3	3	4	4	5	5	5	6
Roof rafter to 2-by ridge beam (driven through beam into end of ridge)	2	3	3	3	N/A	4	4	N/A	N/A	N/A	N/A
Roof rafter to 2-by ridge beam (toe-nail rafter to beam)	2	3	3	3	3	4	4	N/A	N/A	N/A	N/A

See page 38 for footnotes.

Table 26 continued on next page.

**TABLE 26, continued**  
**SUMMARY OF USE OF FASTENERS FOR FRAMING<sup>1</sup>**

Wall Framing											
Top or sole plate to stud (end nailed)	2	3	3	3	5	4	4	N/A	N/A	N/A	N/A
Stud to top or sole plate (toe nailed)	3	4	4	4	4	4	4	5	5	5	5
Cap/top plate laps and intersections (each side of lap)	2	3	3	3	4	3	3	N/A	N/A	N/A	N/A
Diagonal bracing	2	2	2	2	2	3	3	3	4	4	4
Sole plate to joist or blocking @ braced panels (number per 16" joist space)	2	3	3	4	N/A	4	4	N/A	N/A	N/A	N/A
Sole plate to joist or blocking	16" o.c.	8" o.c.	8" o.c.	8" o.c.	6" o.c.	8" o.c.	8" o.c.	N/A	N/A	N/A	N/A
Double top plate	16" o.c.	16" o.c.	12" o.c.	12" o.c.	8" o.c.	12" o.c.	12" o.c.	N/A	N/A	N/A	N/A
Double studs	12" o.c.	12" o.c.	8" o.c.	8" o.c.	6" o.c.	8" o.c.	8" o.c.	N/A	N/A	N/A	N/A
Corner studs	24" o.c.	16" o.c.	16" o.c.	16" o.c.	8" o.c.	12" o.c.	12" o.c.	N/A	N/A	N/A	N/A

N/A - Fastener not applicable to connection

<sup>1</sup>This fastening schedule applies to framing members having an actual thickness of 1½" (nominal "2-by" lumber).

<sup>2</sup>Fastenings listed above may also be used for other connections that are not listed but that have the same configuration and the same code requirement for fastener quantity/spacing and fastener size (pennyweight and style, e.g., 8d common, "8-penny common nail").

<sup>3</sup>Fastening schedule only applies to buildings of conventional wood frame construction where wind or seismic analysis is not required by the applicable code. In areas where wind or seismic analysis is required, required fastening shall be determined by structural analysis. Following are conditions for which codes require structural analysis:

- *International Building Code* - buildings located in areas where design wind speeds exceed 100 mph (161 km/hr) (3-second gust) or 110 mph (177 km/hr) (3-second gust) in Exposure Categories A or B. Structural analysis is also required on buildings assigned to seismic design categories B, C, D or E, with exception of detached Group R-3 dwellings assigned to seismic design category B and some detached R-3 dwellings assigned to seismic design category C.

- *International Residential Code* - buildings located in areas where the design wind speed equals or exceeds 110 mph (177.1 km/h) (3 second gust) or assigned to seismic design categories C, D1 and D2 (with detached one- and two-family dwellings in category C being exempt).

- *BOCA National Building Code* - buildings in any location.

- *Standard Building Code* - buildings located in areas where design wind speeds prescribed exceed 80 mph or which do not qualify for one of the exceptions outlined in Section 1607.1 of the code.

- *SBCCI Standard SSTD 10* - this fastening schedule equivalent to that contained in Appendix E of the standard. However, note that specific provisions in the standard may supercede or supplement this schedule.

- *International One and Two Family Dwelling Code* - buildings other than one story buildings in height in exposure classification A/B unless over 50 feet in height, or with unusual construction or geometric shapes, with overhanging eave projections greater than 24 inches, or located in special wind regions or localities.

- *Uniform Building Code* - buildings located in areas where the design wind speeds prescribed are 80 mph or higher. Sections 2320.4 and 2320.5 of the code for additional requirements in various seismic zones.

**TABLE 27**  
**ALLOWABLE SPACING OF ALTERNATE FASTENINGS<sup>1</sup> FOR THE ATTACHMENT OF**  
**19/32", 5/8", 23/32" & 3/4" <sup>5</sup> WOOD STRUCTURAL PANEL AND PARTICLEBOARD**  
**COMBINATION SUBFLOOR/UNDERLAYMENT**  
**TO WOOD FRAMING MEMBERS**

Fastener Type (Minimum Nominal Nail <sup>2</sup> Shank Diameter, in inches, or Staple <sup>3</sup> Gage)	Minimum Nominal Length, inches	Spacing of Fasteners	
		At Edges (and At Intermediate Supports Where Spans Are 48" or More)	At Intermediate Supports
0.131" nail (8 common nail)	2½	6	12
0.120" deformed shank nail	2		
0.092" nail	2¼	3	6
0.099" nail	2¼	4	8
0.099" deformed shank nail	2¼	4	8
0.113" nail	2	3	6
0.113" deformed shank nail	2	4	8
0.113" nail (8d cooler)	2⅝	4	8
0.113" deformed shank nail	2⅝	4	8
0.120" nail	3	4	8
0.131" deformed shank nail	2½	6	12
16 gage staple	1¾	3	6
	2	4	8
15 gage staple	1¾	3	6
	2	4	8
	2¼		
	2½		
14 gage staple	2	4	8
	2¼		
	2½		
	3		

<sup>1</sup>For fastening of wood structural panel horizontal diaphragms and shear walls refer to design tables (Table 4 through 20) for sufficient lateral strength.

<sup>2</sup>A deformed shank nail shall have either a helical (screw) shank or an annular (ring) shank.

<sup>3</sup>Staples shall have minimum 7/16" crown widths.

<sup>4</sup>In areas using the *Standard Building Code*, only deformed shank nails are permitted to fasten combination subfloor/underlayment.

<sup>5</sup>Thicker panels may be applied but fastener length must be increased by change in panel thickness so that fastener penetration into framing members does not decrease.

## HOW TO USE THE PRESCRIPTIVE SHEATHING TABLES

Prescriptive sheathing tables give fastening requirements for conventional construction where design is not necessary. The prescriptive tables for sheathing are found in these model code tables:

<i>BOCA National Building Code</i> .....	Table 2305.2
<i>International Building Code</i> .....	Table 2304.9.1
<i>International One and Two Family Building Code</i> .....	Tables 602.3(1) and 602.3(2)
<i>International Residential Code</i> .....	Tables R602.3(1) and R602.3(2)
SBCCI Standard SSTD 10 .....	Sections 207.3 and 307.4
<i>Standard Building Code</i> .....	Table 2306.1
<i>Uniform Building Code</i> .....	Tables 23-II-B-1 and 23-II-B-2

Use Tables 28 through 34 for roof sheathing, Table 35 for wall sheathing, and Tables 36 and 37 for floor (subfloor) sheathing to determine which fasteners the applicable model code lists, and on what spacing. Select the table (from Tables 38 through 44) which lists the nail that the code lists and the attachment thickness being used.

### STEP 1 - Determining Code Requirements

The model code requirements are summarized in Tables 28 through 34 for roof sheathing, Table 35 for wall sheathing, and Tables 36 and 37 for floor (subfloor) sheathing. Requirements consist of a fastener (e.g. 8d common nail) and its spacing. (e.g. 12" o.c. at panel edges). Fasteners attaching the "edges" of sheathing to framing members are usually spaced tighter than are the fasteners attaching interior surfaces of the sheathing to "intermediate" supports (framing members).

Requirements vary with the model code.

High wind requirements may depend on additional considerations. High wind requirements vary across the country. For a particular part of the country, the fastening requirements may vary with the area's "basic wind speed". In high wind areas, the fastening requirements may vary with average roof height, roof slope, roof style (hip roof versus gable-end roof) and the spacing between framing members. Requirements may be different for different parts of the roof, such as areas near ridges, eaves, rakes and gable ends.

### STEP 2 - Equivalent Fastening Tables

After code requirements are determined in the form of a fastener and its spacing from Tables 28 through 37, Tables 38 through 44 may be used to determine the spacing of other fasteners which will result in the same or larger withdrawal strengths along each framing member. Each table applies to one sheathing thickness or a limited range of sheathing thicknesses. Each table presents, for one fastener listed in the model codes, the allowable maximum spacings of listed alternate fasteners.

#### Example

The BOCA National Building Code requirement for fastening ½" structural panels for floors (subfloors) (Table 36) is a 6d common nail spaced 6" o.c. at panel edges and 12" o.c. at intermediate framing members. (See the upper left-hand corner of the table.) Table 39 lists a 1½" 16 Gage staple spaced 4" o.c. at panel edges and 8" o.c. at intermediate framing members as an allowable equivalent.

**TABLE 28**  
**ROOF SHEATHING NAILING REQUIREMENTS<sup>3,4</sup>**  
**BOCA NATIONAL BUILDING CODE**  
**General Fastener Spacing, Spacing at Gable End Wall Framing (GEWF) and**  
**Spacing Within 48" of Ridges, Eaves and Gable End Walls (R,E,GEW)**

Wood Structural Panel Nominal Thickness	Basic Wind Speed (mph)		
	90 or less	Over 90 to 120	Over 120
5/8" or less	8d common <sup>1</sup>  <u>Span &lt; 32" o.c.</u> 6" o.c./ 12" o.c.  <u>Span 32" or &gt; o.c.</u> 6" o.c./ 12" o.c. general 6" o.c. to GEWF 6" o.c./ 6" o.c. within 48" of R,E,GEW	8d common <sup>1</sup>  <u>Span &lt; 48" o.c.</u> 6" o.c./ 12" o.c. general 6" o.c. to GEWF 6" o.c./ 6" o.c. within 48" of R,E,GEW  <u>Span 48" or &gt; o.c.</u> 6" o.c./ 12" o.c. general 6" o.c. to GEWF 4" o.c./ 4" o.c. within 48" of R,E,GEW	<u>General Spacing</u> 8d common <sup>1</sup> 6" o.c./ 6" o.c.  <u>Spacing at GEWF</u> 8d common <sup>1</sup> 4" o.c.  <u>Spacing within 48" of R,E,GEW</u> 8d deformed shank nail <sup>2</sup> 6" o.c./ 6" o.c.
over 5/8"	8d common <sup>1</sup>  <u>Span &lt; 48" o.c.</u> 6" o.c./ 12" o.c. general 6" o.c. to GEWF 6" o.c./ 6" o.c. within 48" of R,E,GEW  <u>Span 48" or &gt; o.c.</u> 6" o.c./ 6" o.c. general 6" o.c. to GEWF 4" o.c./ 4" o.c. within 48" of R,E,GEW	<u>Span &lt; 32" o.c.</u> 8d common <sup>1</sup> 6" o.c./ 12" o.c. general 6" o.c. to GEWF 6" o.c./ 6" o.c. within 48" of R,E,GEW  <u>Span of 32" o.c.</u> 8d common <sup>1</sup> 6" o.c./ 6" o.c. general 4" o.c. to GEWF 4" o.c./ 4" o.c. within 48" of R,E,GEW  <u>Span of 48" o.c.</u> 10d common 6" o.c./ 6" o.c. general 6" o.c. to GEWF 4" o.c./ 4" o.c. within 48" of R,E,GEW	<u>Span &lt; 32" o.c.</u> 8d common <sup>1</sup> 6" o.c./ 6" o.c. general 4" o.c. to GEWF  6d deformed shank nail 6" o.c./ 6" o.c. within 48" of R,E,GEW  <u>Span of 32" o.c.</u> 10d common 6" o.c./ 6" o.c. general 4" o.c. to GEWF  10d deformed shank nail 4" o.c./ 4" o.c. within 48" of R,E,GEW  <u>Span of 48" o.c.</u> 10d deformed shank nail 6" o.c./ 6" o.c. general 4" o.c. to GEWF 3" o.c./ 3" o.c. within 48" of R,E,GEW

<sup>1</sup>Alternate fasteners and their spacings to achieve equivalent performance to an 8d common shank nails are found in Tables 40 and 43 for various sheathing panel thicknesses.

<sup>2</sup>Alternate fasteners and their spacing to achieve equivalent performance to an 8d deformed shank nail are found in Tables 41 and 44 for various sheathing panel thicknesses.

<sup>3</sup>Roof panels with spans greater than 48 inches o.c. or roofs with a mean height greater than 35 feet shall be designed according to the wind loads of Section 1609.0.

<sup>4</sup>Where 10d nails are space 3 inches o.c., framing shall be 3 inch nominal in width and nails shall be staggered.

**TABLE 29**  
**ROOF SHEATHING STAPLING REQUIREMENTS<sup>1</sup>**  
**BOCA NATIONAL BUILDING CODE**  
**General Fastener Spacing, Spacing at Gable End Wall Framing (GEWF) and**  
**Spacing Within 48" of Ridges, Eaves and Gable End Walls (R,E,GEW)**

Wood Structural Panel Nominal Thickness	Basic Wind Speed (mph)	
	90 or less	Over 90 to 120
$\frac{5}{8}$ " or less	2 " 16 gage corrosion resistant staple 4" o.c./ 8" o.c., general 4" o.c. to GEWF when spans are 32" o.c. or more 4" o.c. within 48" of R,E,GEW when spans are 32" o.c. or more	2 " 16 gage corrosion resistant staple 4" o.c./ 8" o.c., general 4" o.c. to GEWF 4" o.c. within 48" of R,E,GEW, but 2" o.c. when spans are 48" o.c.

<sup>1</sup>Staples shall have a minimum crown width of  $\frac{7}{16}$  inch and a minimum length of 2 inches.

**TABLE 30**  
**ROOF SHEATHING FASTENING REQUIREMENTS<sup>1</sup>**  
**INTERNATIONAL BUILDING CODE**

Panel Nominal Thickness	Fastener	Maximum Fastener Spacing	
		Spacing less than 48" o.c.	Spacing 48" o.c. or greater
$\frac{1}{2}$ " and less	8d box nail	6" o.c./ 12" o.c.	6" o.c./ 6" o.c.
	$2\frac{3}{8}$ " x .113" nail	4" o.c./ 8" o.c.	
	$1\frac{3}{4}$ " 16 Ga. Staple <sup>2</sup>	3" o.c./ 6" o.c.	
$\frac{19}{32}$ " - $\frac{3}{4}$ "	8d common nail (See Table 43) 6d deformed shank nail	6" o.c./ 12" o.c.	6" o.c./ 6" o.c.
	$2\frac{3}{8}$ " x .113" nail	4" o.c./ 8" o.c.	
	2" 16 Ga. Staple <sup>2</sup>	4" o.c./ 8" o.c.	
$\frac{7}{8}$ " - 1"	8d common nail 8d deformed shank nail	6" o.c./ 12" o.c.	6" o.c./ 6" o.c.
$1\frac{1}{8}$ " - $1\frac{1}{4}$ "	10d common nail 8d deformed shank nail	6" o.c./ 12" o.c.	6" o.c./ 6" o.c.

<sup>1</sup>Table is limited to application on buildings of conventional wood frame construction and associated limitations noted in Section 2308 of the *International Building Code*.

<sup>2</sup>Staples shall have a minimum crown width of  $\frac{7}{16}$ " and a minimum length of 2 inches.

**TABLE 31  
ROOF SHEATHING FASTENING REQUIREMENTS  
FOR THE INTERNATIONAL RESIDENTIAL CODE (IRC)  
AND THE INTERNATIONAL ONE AND TWO FAMILY DWELLING CODE (IOTFDC)**

Panel Nominal Thickness	Nail	Maximum Fastener Spacing <sup>1</sup>
$\frac{5}{16}$ " - $\frac{1}{2}$ "	8d common <sup>2</sup> (See Table 40)	6" o.c./ 12" o.c. <sup>3</sup>
$\frac{19}{32}$ " - 1"	8d common (See Table 43)	6" o.c./ 12" o.c. <sup>3</sup>
$1\frac{1}{8}$ " - $1\frac{1}{4}$ "	10d common 8d deformed shank	6" o.c./ 12" o.c.

<sup>1</sup>Nails shall be spaced at not more than 6 inches on center at all supports where spans are 48 inches or greater.

<sup>2</sup>For regions having basic wind speed of 110 mph (90 mph for IOTFDC) or greater, 8d deformed nails shall be used for attaching plywood and wood structural panel roof sheathing to framing within minimum 48-inch distance from gable end walls, if mean roof height is more than 25 feet, up to 35 feet maximum.

<sup>3</sup>For regions having basic wind speed of 100 mph (80 mph for IOTFDC) or less, nails for attaching wood structural panel roof sheathing to gable end wall framing shall be spaced 6 inches on center. When basic wind speed is greater than 80 mph, nails for attaching panel roof sheathing to intermediate supports shall be spaced 6 inches on center for minimum 48-inch distance from ridges, eaves and gable end walls; and 4 inches on center to gable end wall framing.

**TABLE 32  
ROOF SHEATHING FASTENING REQUIREMENTS <sup>1</sup>  
STANDARD BUILDING CODE**

Panel Nominal Thickness	Fastener	Maximum Fastener Spacing
$\frac{5}{16}$ " - $\frac{1}{2}$ "	8d common nail (see Table 40)	6" o.c./ 12" o.c.
	16 gage galvanized staple <sup>2</sup> Length of 1" plus sheathing thickness	4" o.c./ 8" o.c.
$\frac{19}{32}$ " - $\frac{3}{4}$ "	8d common nail (see Table 43)	6" o.c./ 12" o.c.
	16 gage galvanized staple <sup>1</sup> Length of 1" plus sheathing thickness	2" o.c./ 5" o.c.

<sup>1</sup>Table is limited to application on buildings of conventional wood frame construction where wind or seismic analysis is not required by the code. In areas where design wind speeds prescribed by the code exceed 80 mph, or seismic analysis is required, required fastening shall be determined by structural analysis, based on the allowable fastener loads and allowable diaphragm capacities noted in this report.

<sup>2</sup>Staples shall have a minimum crown width of  $\frac{3}{8}$ "

**TABLE 33  
ROOF SHEATHING FASTENING REQUIREMENTS  
SBCCI STANDARD FOR HURRICANE RESISTANT RESIDENTIAL CONSTRUCTION SSTD 10**

Connection <sup>1</sup>	Basic Wind Speed (mph)	Species Group of Framing Members	Nail	Maximum Fastener Spacing
Zone 1	90 or less	Any	8d common <sup>2</sup> 8d hot dip galvanized box	6" o.c./ 12" o.c.
	Over 90 but not over 100	I or II		6" o.c./ 12" o.c.
		III or IV		6" o.c./ 6" o.c.
	Over 100	Any		6" o.c./ 6" o.c.
Zone 2	All	Any	8d common <sup>2</sup> 8d hot dip galvanized box	6" o.c./ 6" o.c.
Zone 3	Less than 100	Any	8d common <sup>2</sup> 8d hot dip galvanized box	6" o.c./ 6" o.c.
	100 or more but less than 110	I or II	8d common <sup>2</sup> 8d hot dip galvanized box	
		III or IV	8d ring shank <sup>3</sup>	
	110 or more	Any	8d ring shank <sup>3</sup>	
Sheathing to gable end wall framing or to gable truss	All	Any	8d common <sup>3</sup> 8d hot dip galvanized box	4" o.c.

<sup>1</sup>Roof sheathing nailing zones are described below:

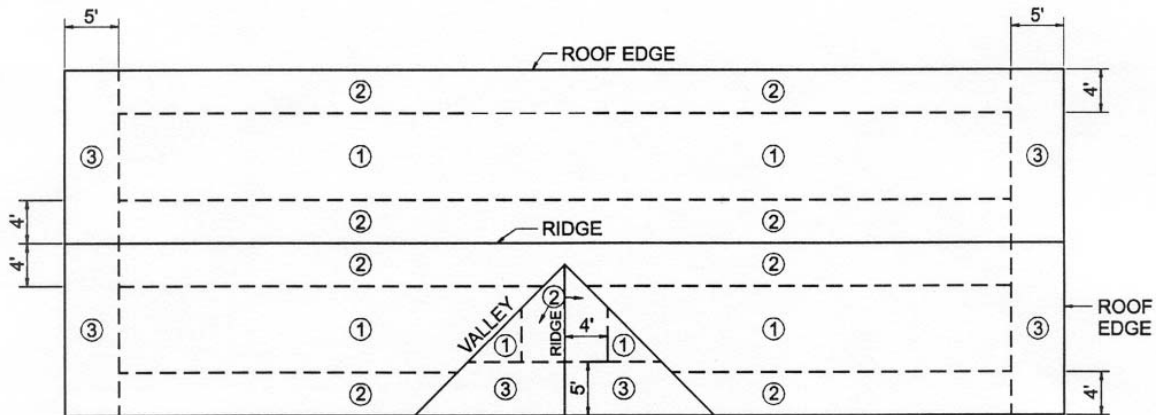

<sup>2</sup>Alternate fasteners and their spacings to achieve equivalent performance to an 8d common nail are found in Tables 40 and 43 for various sheathing panel thicknesses.

<sup>3</sup>Alternate fasteners and their spacings to achieve equivalent performance to an 8d ring shank nail are found in Tables 41 and 44 for various sheathing panel thicknesses.

**TABLE 34  
ROOF SHEATHING FASTENING REQUIREMENTS<sup>1</sup>  
UNIFORM BUILDING CODE**

Wind Region	Nail	Panel Fastening Location	Roof Fastening Zone <sup>2</sup>		
			1	2	3
			Fastening Schedule (inches on center)		
			x 25.4 for mm		
Greater than 90 mph (145 km/h)	8d common (see Tables 40 and 43)	Panel edges <sup>3</sup>	6	6	4 <sup>4</sup>
		Panel field	6	6	6 <sup>4</sup>
Greater than 80 mph (129 km/h) to 90 mph (145 km/h)		Panel edges <sup>3</sup>	6	6	4
Panel field		12	6	6	
80 mph (129 km/h) or less		Panel edges <sup>3</sup>	6	6	6
		Panel field	12	12	12

<sup>1</sup>Applies only to mean roof heights up to 35 feet (10 700 mm). For mean roof heights over 35 feet (10 700 mm), the nailing shall be designed.

<sup>2</sup>The roof fastening zones are show below:

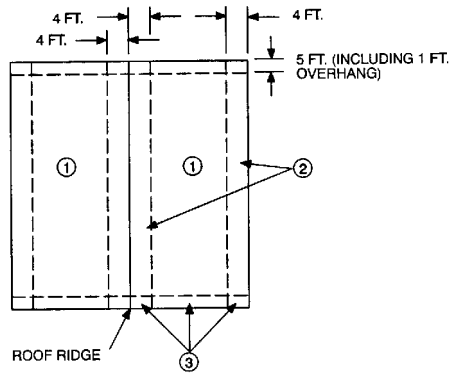

<sup>3</sup>Edge spacing also applies over roof framing at gable-end walls.

<sup>4</sup>Use 8d ring-shank nails in this zone if mean roof height is greater than 25 feet (7600 mm).

**TABLE 35  
MODEL CODE WALL SHEATHING PRESCRIPTIVE REQUIREMENTS  
FOR USE IN SELECTING ALTERNATE FASTENINGS WITH TABLES 38 THROUGH 44**

Wood Structural Panel Nominal Thickness	Model Code Fastener and Spacing (at panel edges/intermediate)				
	BOCA/NBC <sup>8</sup> (Table 2305.2)	IOTFDC <sup>1</sup> (Tables 602.3(1) & 602.3(2)) IRC <sup>1</sup> (Table R602.3(1))	SBC <sup>4</sup> (Table 2306.1)	UBC <sup>6</sup> (Table 23-II-B-1)	IBC <sup>7</sup> (Table 2304.9.1)
½" or less	6d common nail (see Table 39),  or 2" 16 gage staple  6" o.c./ 12" o.c.	6d common nail (see Table 39) 6" o.c./ 12" o.c.  <u>Also, for IOTFDC</u> 1½" 15 gage staple <sup>3</sup> 6" o.c./ 12" o.c. or 1⅝" x .099" nail 3" o.c./ 6" o.c.	6d common nail (see Table 39) 6" o.c./ 12" o.c.  or, 16 gage staple <sup>5</sup> , length of 1" plus panel thickness 4" o.c./ 8" o.c.	6d box nail (see Table 38) 6" o.c./ 12" o.c. <sup>2</sup>	6d box nail (see Table 38), or 2⅝" x .113" nail 6" o.c./ 12" o.c. <sup>2</sup>  or 1¾" 16 gage staple <sup>3</sup> 4" o.c./ 8" o.c.
19/32 - 5/8	8d common nail (see Table 43) 6" o.c./ 12" o.c. <sup>2</sup>  or, 2" 16 gage staple 4" o.c./ 8" o.c.	8d common nail (see Table 43) 6" o.c./ 12" o.c.  <u>Also, for IOTFDC</u> 1⅞" x .113" nail, or 1⅝" 15 or 16 gage staple <sup>3</sup> 6" o.c./ 12" o.c. or 1¾" x .099" nail 3" o.c./ 6" o.c.	8d common nail (see Table 43) 6" o.c./ 12" o.c.  or, 16 gage staple <sup>5</sup> , length of 1" plus panel thickness 2" o.c./ 5" o.c.	8d box nail (see Table 42) 6" o.c./ 12" o.c. <sup>2</sup>	8d box nail (see Table 42) 6" o.c./ 12" o.c. <sup>2</sup>  or, 2" 16 gage staple <sup>3</sup> 4" o.c./ 8" o.c.
¾"	8d common nail (see Table 43) 6" o.c./ 12" o.c. <sup>2</sup>	8d common nail (see Table 43), 6" o.c./ 12" o.c. <u>Also, for IOTFDC</u> 1¾" 15 gage staple <sup>3</sup> 5" o.c./ 10" o.c. or 1⅞" x .099" nail 3" o.c./ 6" o.c.			2⅝" x .113" nail 4" o.c./ 8" o.c.

<sup>1</sup>Four-foot by 8-foot or 4-foot by 9-foot panels shall be applied vertically.

<sup>2</sup>Intermediate spacing shall be 6" on center at supports when spans are 48" or more.

<sup>3</sup>Staple crown shall be a minimum 7/16" width, overall, unless otherwise stated.

<sup>4</sup>In areas using the *Standard Building Code*, use of this table is limited to buildings of conventional wood frame construction where wind or seismic analysis is not required by the code. In areas where design wind speeds prescribed by the code exceed 80 mph or where seismic analysis is required, required fastening shall be determined by structural analysis based on the allowable fastener loads and allowable diaphragm capacities noted in this report. When applicable, use of prescriptive fastening schedules in SBCCI SSTD 10 is permitted, with alternative fasteners selected from Tables 38 through 44.

<sup>5</sup>Staple crown shall be a minimum 3/8" width, overall.

<sup>6</sup>Table is limited to application on buildings of conventional wood frame construction and associated limitations noted in Section 2320 of the *Uniform Building Code*.

<sup>7</sup>Table is limited to application on buildings of conventional wood frame construction and associated limitations noted in Section 2308 of the *International Building Code*.

<sup>8</sup>Table is a minimum fastening schedule for buildings of conventional wood frame construction in areas governed by the *BOCA National Building Code*. Actual design shall be validated by structural analysis.

**TABLE 36**  
**MODEL CODE SUBFLOOR SHEATHING PRESCRIPTIVE REQUIREMENTS<sup>1,3</sup>**  
**FOR USE IN SELECTING ALTERNATE FASTENINGS WITH TABLES 38 THROUGH 44**  
**National, Standard and Uniform Building Codes**

Wood Structural Panel Nominal Thickness	Model Code Fastener and Spacing (at panel edges/intermediate)		
	BOCA/NBC <sup>8</sup> (Table 2305.2)	SBC <sup>4,6</sup> (Table 2306.1)	UBC <sup>7</sup> (Table 23-II-B-1)
½" or less	6d common nail (see Table 39), or 6d deformed shank nail 6" o.c./ 12" o.c.  or,  1⅝" 16 gage staple <sup>5</sup> 4" o.c./ 7" o.c.	6d common nail (see Table 39), or 6d deformed shank nail 6" o.c./ 12" o.c.  or,  1⅝" 16 gage staple <sup>5</sup> 4" o.c./ 7" o.c.	6d common nail (see Table 39), or 6d deformed shank nail 6" o.c./ 12" o.c. <sup>2</sup>
<sup>19</sup> / <sub>32</sub> - <sup>5</sup> / <sub>8</sub>	8d common nail (see Table 43), or 6d deformed shank nail 6" o.c./ 12" o.c.  or,  1⅝" 16 gage staple <sup>5</sup> , 2½" o.c./ 4" o.c.	8d common nail (see Table 43), or 6d deformed shank nail 6" o.c./ 12" o.c.  or,  1⅝" 16 gage staple <sup>5</sup> , 2½" o.c./ 4" o.c.	8d common nail (see Table 43), or 6d deformed shank nail 6" o.c./ 12" o.c. <sup>2</sup>
¾	8d common nail (see Table 43), or 6d deformed shank nail 6" o.c./ 12" o.c.	8d common nail (see Table 43), or 6d deformed shank nail 6" o.c./ 12" o.c.	

<sup>1</sup>A deformed shank nail shall have either a helical (screw) shank or an annular (ring) shank.

<sup>2</sup>Intermediate spacing shall be 6" on center at supports when spans are 48" or more.

<sup>3</sup>Staple crown shall be a minimum <sup>7</sup>/<sub>16</sub>" width, overall, unless otherwise stated.

<sup>4</sup>In areas using the *Standard Building Code*, use of this table is limited to buildings of conventional wood frame construction where wind or seismic analysis is not required by the code. In areas where design wind speeds prescribed by the code exceed 80 mph or where seismic analysis is required, required fastening shall be determined by structural analysis based on the allowable fastener loads and allowable diaphragm capacities noted in this report. When applicable, use of prescriptive fastening schedules in SBCCI Standard SSTD 10 is permitted, with alternative fasteners selected from Tables 38 through 44.

<sup>5</sup>Staple crown shall be a minimum <sup>3</sup>/<sub>8</sub>" width, overall.

<sup>6</sup>In areas using the *Standard Building Code* and SBCCI SSTD 10 only deformed shank nails are permitted to fasten combination subfloor/underlayment.

<sup>7</sup>Table is limited to application on buildings of conventional wood frame construction and associated limitations noted in Section 2320 of the *Uniform Building Code*.

<sup>8</sup>Table is a minimum fastening schedule for buildings of conventional wood frame construction in areas governed by the *BOCA National Building Code*. Actual design shall be validated by structural analysis.

**TABLE 37**  
**MODEL CODE SUBFLOOR SHEATHING PRESCRIPTIVE REQUIREMENTS<sup>1</sup>**  
**FOR USE IN SELECTING ALTERNATE FASTENINGS WITH TABLES 38 THROUGH 44**  
**International Codes**

Wood Structural Panel Nominal Thickness	Model Code Fastener and Spacing (at panel edges/intermediate)		
	IOTFDC (Tables 602.3(1) & 602.3(2))	IBC <sup>3</sup> (Table 2304.9.1)	IRC (Tables R602.3(1) and R602.3(2))
½" or less	6d common nail (see Table 39) 6" o.c./ 12" o.c. <sup>2</sup> or, 1½" 15 gage staple 6" o.c./ 10" o.c. <sup>2</sup> or, 1⅝" 0.099 Nail 3" o.c./ 6" o.c.	6d common nail (see Table 39), or 2⅜" x .113" nail 6" o.c./ 12" o.c. <sup>2</sup> or, 1¾" 16 gage staple, 4" o.c./ 8" o.c.	6d common nail (see Table 39) 6" o.c./ 12" o.c. <sup>2</sup> or 1¾" 16 gage staple 6" o.c./ 12" o.c. or 1⅝" 0.099 Nail 3" o.c./ 6" o.c.
19/32" - 5/8"	8d common nail (see Table 43) 6" o.c./ 12" o.c. <sup>2</sup> or, 1⅞" 0.113" nail, or 1⅝" 15 or 16 gage staple 6" o.c./ 10" o.c. <sup>2</sup> or, 1¾" 0.099" Nail 3" o.c./ 6" o.c.	8d common nail (see Table 43) 6" o.c./ 12" o.c. <sup>2</sup> or, 2" 16 gage staple, or 4" o.c./ 8" o.c. or, 2⅜" x .113" nail 4" o.c./ 8" o.c. <sup>2</sup>	8d common nail (see Table 43), or 1⅞" 0.113" nail 6" o.c./ 12" o.c. <sup>2</sup> or 1⅝" 15 or 16 gage staple 6" o.c./ 12" o.c. or, 1¾" 0.099" Nail 3" o.c./ 6" o.c.
23/32" - 3/4"	8d common nail (see Table 43) 6" o.c./ 12" o.c. <sup>2</sup> or, 1¾" 14 gage staple 6" o.c./ 10" o.c. <sup>2</sup> or, 1¾" 15 gage staple 5" o.c./ 10" o.c. <sup>2</sup> or, 1⅞" 0.099" Nail 3" o.c./ 6" o.c.	2" 16 gage staple, or 4" o.c./ 8" o.c. or, 2⅜" x .113" nail 4" o.c./ 8" o.c. <sup>2</sup>	8d common nail (see Table 43), 6" o.c./ 12" o.c. <sup>2</sup> or, 2" 16 gage staple 4" o.c./ 8" o.c. or, 1¾" 15 gage staple 5" o.c./ 10" o.c. or, 1⅞" 0.099" Nail 3" o.c./ 6" o.c.

<sup>1</sup>Staple crown shall be a minimum  $\frac{7}{16}$ " width, overall.

<sup>2</sup>Intermediate spacing shall be 6" on center at supports when spans are 48" or more.

<sup>3</sup>Table is limited to application on buildings of conventional wood frame construction and associated limitations noted in Section 2308 of the *International Building Code*.

**TABLE 38**  
**ALLOWABLE SPACING OF ALTERNATE FASTENINGS<sup>1</sup> EQUIVALENT TO THE ATTACHMENT OF**  
**½" AND THINNER WALL WOOD STRUCTURAL PANEL AND PARTICLEBOARD SHEATHING TO**  
**WOOD FRAMING MEMBERS USING A 6D BOX NAIL**

Fastener Type (Minimum Nominal Nail <sup>2</sup> Shank Diameter, in inches, or Staple <sup>3</sup> Gage)	Minimum Nominal Length, inches	If Model Code Requires		
		6d Box Nail Spaced 4" o.c.	6d Box Nail Spaced 6" o.c.	6d Box Nail Spaced 12" o.c.
0.099" nail (6d box nail)	2	4	6	12
0.092" nail	2¼	3	4	8
0.099" nail	2¼	4	6	12
0.099" deformed shank nail	2¼	4	6	12
0.113" nail	2	4	6	12
0.113" deformed shank nail	2	4	6	12
0.113" nail (8d cooler)	2¾	4	6	12
0.113" deformed shank nail	2¾	4	6	12
0.120" nail	3	4	8	16
0.131" nail (8d common)	2½	6	8	16
0.131" deformed shank nail	2½	6	8	16
16 gage staple	1½	3	4	8
	1¾	4	6	12
	2			
15 gage staple	1¾	4	6	12
	2			
	2¼			
	2½			
14 gage staple	2	4	8	16
	2¼			
	2½			
	3			

<sup>1</sup>For fastening of wood structural panel horizontal diaphragms and shear walls refer to design tables (Table Numbers 4 through 20) for sufficient lateral strength.

<sup>2</sup>A deformed shank nail shall have either a helical (screw) shank or an annular (ring) shank.

<sup>3</sup>Staples shall have minimum 7/16" crown widths.

**TABLE 39**  
**ALLOWABLE SPACING OF ALTERNATE FASTENINGS<sup>1</sup> EQUIVALENT TO THE ATTACHMENT OF**  
**½" AND THINNER WOOD STRUCTURAL PANEL AND PARTICLEBOARD SHEATHING TO**  
**WOOD FRAMING MEMBERS USING A 6D COMMON NAIL**

Fastener Type (Minimum Nominal Nail <sup>2</sup> Shank Diameter, in inches, or Staple <sup>3</sup> Gage)	Minimum Nominal Length, inches	If Model Code Requires		
		6d Common Nail Spaced 4" o.c.	6d Common Nail Spaced 6" o.c.	6d Common Nail Spaced 12" o.c.
0.113" nail (6d common nail)	2	4	6	12
0.092" nail	2¼"	2	4	8
0.099" nail	2¼"	3	4	8
0.099" deformed shank nail	2¼"	3	4	8
0.113" nail	2	4	6	12
0.113" deformed shank nail	2	4	6	12
0.113" nail (8d cooler)	2⅝"	4	6	12
0.113" deformed shank nail	2⅝"	4	6	12
0.120" nail	3	4	6	12
0.131" nail (8d common)	2½"	4	8	12
0.131" deformed shank nail	2½"	4	8	12
16 gage staple	1½"	3	4	8
	1¾"			
	2"			
15 gage staple	1¾"	4	6	12
	2"			
	2¼"			
	2½"			
14 gage staple	2"	4	6	12
	2¼"			
	2½"			
	3"			

<sup>1</sup>For fastening of wood structural panel horizontal diaphragms and shear walls refer to design tables (Table Numbers 4 through 20) for sufficient lateral strength.

<sup>2</sup>A deformed shank nail shall have either a helical (screw) shank or an annular (ring) shank.

<sup>3</sup>Staples shall have minimum 7/16" crown widths.

**TABLE 40**  
**ALLOWABLE SPACING OF ALTERNATE FASTENINGS<sup>1</sup> EQUIVALENT TO**  
**THE ATTACHMENT OF ½" AND THINNER WOOD STRUCTURAL PANEL AND**  
**PARTICLEBOARD SHEATHING TO WOOD FRAMING MEMBERS USING AN 8D COMMON NAIL**

Fastener Type (Minimum Nominal Nail <sup>2</sup> Shank Diameter, in inches, or Staple <sup>3</sup> Gage)	Minimum Nominal Length, inches	If Model Code Requires		
		8d Common Nail Spaced 4" o.c.	8d Common Nail Spaced 6" o.c.	8d Common Nail Spaced 12" o.c.
0.131" nail (8d common nail)	2½	4	6	12
0.092" nail	2¼	2	3	6
0.099" nail	2¼	2	3	6
0.099" deformed shank nail	2¼	2	3	6
0.113" nail	2	2	4	8
0.113" deformed shank nail	2	2	4	8
0.113" nail (8d cooler)	2⅜	3	4	8
0.113" deformed shank nail	2⅜	3	4	8
0.120" nail	3	3	4	8
0.131" deformed shank nail	2½	4	6	12
16 gage staple	1¾	2	3	6
	2			
15 gage staple	1¾	2	4	8
	2			
	2¼			
	2½			
14 gage staple	2	3	4	8
	2¼			
	2½			
	3			

<sup>1</sup>For fastening of wood structural panel horizontal diaphragms and shear walls refer to design tables (Table Numbers 4 through 20) for sufficient lateral strength.

<sup>2</sup>A deformed shank nail shall have either a helical (screw) shank or an annular (ring) shank.

<sup>3</sup>Staples shall have minimum 7/16" crown widths.

**TABLE 41  
ALLOWABLE SPACING OF ALTERNATE FASTENINGS<sup>1</sup> EQUIVALENT TO THE ATTACHMENT OF ½" AND THINNER  
WOOD STRUCTURAL PANEL AND PARTICLEBOARD SHEATHING TO WOOD FRAMING MEMBERS  
USING AN 8D DEFORMED SHANK NAIL**

Fastener Type (Minimum Nominal Nail <sup>2</sup> Shank Diameter, in inches, or Staple <sup>3</sup> Gage)	Minimum Nominal Length, inches	If Model Code Requires		
		8d Deformed Shank Nail Spaced 4" o.c.	8d Deformed Shank Nail Spaced 6" o.c.	8d Deformed Shank Nail Spaced 12" o.c.
0.120" nail ( 8d deformed shank nail)	2½	4	6	12
0.092" nail	2¼	2	3	6
0.099" nail	2¼	2	4	8
0.099" deformed shank nail	2¼	3	4	8
0.113" nail	2	2	3	6
0.113" deformed shank nail	2	2	4	8
0.113" nail ( 8d cooler)	2⅞	3	4	8
0.113" deformed shank nail	2⅞	3	4	8
0.120" nail	3	4	6	12
0.131" nail ( 8d common)	2½	4	6	12
0.131" deformed shank nail	2½	4	6	12
16 gage staple	1¾	2	3	6
	2			
15 gage staple	1¾	2	4	8
	2			
	2¼			
	2½			
14 gage staple	2	3	4	8
	2¼			
	2½			
	3			

<sup>1</sup>For fastening of wood structural panel horizontal diaphragms and shear walls refer to design tables (Table Numbers 4 through 20) for sufficient lateral strength.

<sup>2</sup>A deformed shank nail shall have either a helical (screw) shank or an annular (ring) shank.

<sup>3</sup>Staples shall have minimum 7/16" crown widths.

**TABLE 42**  
**ALLOWABLE SPACING OF ALTERNATE FASTENINGS<sup>1</sup> EQUIVALENT TO THE ATTACHMENT OF 19/32", 5/8", 23/32"**  
**& 3/4" WALL WOOD STRUCTURAL PANEL AND PARTICLEBOARD SHEATHING TO WOOD FRAMING MEMBERS**  
**USING AN 8D BOX NAIL**

Fastener Type (Minimum Nominal Nail <sup>2</sup> Shank Diameter, in inches, or Staple <sup>3</sup> Gage)	Minimum Nominal Length, inches	If Model Code Requires		
		8d Box Nail Spaced 4" o.c.	8d Box Nail Spaced 6" o.c.	8d Box Nail Spaced 12" o.c.
0.113" nail (8 box nail)	2½	4	6	12
0.092" nail	2¼	2	4	8
0.099" nail	2¼	3	4	8
0.099" deformed shank nail	2¼	3	4	8
0.113" nail	2	2 (See footnote 4)	4	8
0.113" deformed shank nail	2	3	4	8
0.113" nail (8d cooler)	2¾	3	4	8
0.113" deformed shank nail	2¾	4	6	12
0.120" nail	3	4	6	12
0.131" nail (8d common)	2½	4	6	12
0.131" deformed shank nail	2½	4	6	12
16 gage staple	1¾	2	3 (See footnote 5)	6 (See footnote 6)
	2	3	4	8
15 gage staple	1¾	3	4	8
	2			
	2¼			
	2½			
14 gage staple	2	4	6	12
	2¼			
	2½			
	3			

<sup>1</sup>For fastening of wood structural panel horizontal diaphragms and shear walls refer to design tables (Table Numbers 4 through 20) for sufficient lateral strength.

<sup>2</sup>A deformed shank nail shall have either a helical (screw) shank or an annular (ring) shank.

<sup>3</sup>Staples shall have minimum 7/16" crown widths.

<sup>4</sup>Spacing for 19/32" and 5/8" panel thicknesses up to 3" o.c. is permitted.

<sup>5</sup>Spacing for 19/32" and 5/8" panel thicknesses up to 4" o.c. is permitted.

<sup>6</sup>Spacing for 19/32" and 5/8" panel thicknesses up to 8" o.c. is permitted.

**TABLE 43**  
**ALLOWABLE SPACING OF ALTERNATE FASTENINGS<sup>1</sup> EQUIVALENT TO THE ATTACHMENT OF 19/32", 5/8", 23/32"**  
**& 3/4" WOOD STRUCTURAL PANEL AND PARTICLEBOARD SHEATHING TO WOOD FRAMING MEMBERS**  
**USING AN 8D COMMON NAIL**

Fastener Type (Minimum Nominal Nail <sup>2</sup> Shank Diameter, in inches, or Staple <sup>3</sup> Gage)	Minimum Nominal Length, inches	If Model Code Requires		
		8d Common Nail Spaced 4" o.c.	8d Common Nail Spaced 6" o.c.	8d Common Nail Spaced 12" o.c.
0.131" nail (8 common nail)	2½	4	6	12
0.092" nail	2¼	2	3	6
0.099" nail	2¼	2	4	8
0.099" deformed shank nail	2¼	2	4	8
0.113" nail	2	2	3	6
0.113" deformed shank nail	2	2	4	8
0.113" nail (8d cooler)	2⅜	3	4	8
0.113" deformed shank nail	2⅜	3	4	8
0.120" nail	3	3	4	8
0.131" deformed shank nail	2½	4	6	12
16 gage staple	1¾	2	3	6
	2	2	4	8
15 gage staple	1¾	2	3 (See footnote 4)	6 (See footnote 5)
	2	3	4	8
	2¼			
	2½			
14 gage staple	2	3	4	8
	2¼			
	2½			
	3			

<sup>1</sup>For fastening of wood structural panel horizontal diaphragms and shear walls refer to design tables (Table Numbers 4 through 20) for sufficient lateral strength.

<sup>2</sup>A deformed shank nail shall have either a helical (screw) shank or an annular (ring) shank.

<sup>3</sup>Staples shall have minimum 7/16" crown widths.

<sup>4</sup>Spacing for 19/32" and 5/8" panel thicknesses up to 4" o.c. is permitted.

<sup>5</sup>Spacing for 19/32" and 5/8" panel thicknesses up to 8" o.c. is permitted.

**TABLE 44**  
**ALLOWABLE SPACING OF ALTERNATE FASTENINGS<sup>1</sup> EQUIVALENT TO THE ATTACHMENT OF**  
**19/32", 5/8", 23/32" AND 3/4" WOOD STRUCTURAL PANEL AND PARTICLEBOARD SHEATHING**  
**TO WOOD FRAMING MEMBERS USING AN 8D DEFORMED SHANK NAIL**

Fastener Type (Minimum Nominal Nail <sup>2</sup> Shank Diameter, in inches, or Staple <sup>3</sup> Gage)	Minimum Nom- inal Length, inches	If Model Code Requires		
		8d Deformed Shank Nail Spaced 4" o.c.	8d Deformed Shank Nail Spaced 6" o.c.	8d Deformed Shank Nail Spaced 12" o.c.
0.120" nail ( 8d deformed shank nail)	2½	4	6	12
0.092" nail	2¼	2	3	6
0.099" nail	2¼	2	3 (See footnote 5)	6 (See footnote 4)
0.099" deformed shank nail	2¼	2	4	8
0.113" nail	2	2	3	6
0.113" deformed shank nail	2	2	4	8
0.113" nail ( 8d cooler)	2¾	3	4	8
0.113" deformed shank nail	2¾	3	4	8
0.120" nail	3	4	6	12
0.131" nail ( 8d common)	2½	4	6	12
0.131" deformed shank nail	2½	4	6	12
16 gage staple	1¾	2	3	6
	2	2	4	8
15 gage staple	1¾	2	3 (See note 5)	6 (See note 4)
	2	3	4	8
	2¼			
	2½			
14 gage staple	2	3	4	8
	2¼			
	2½			
	3			

<sup>1</sup>For fastening of wood structural panel horizontal diaphragms and shear walls refer to design tables (Table Numbers 4 through 20) for sufficient lateral strength.

<sup>2</sup>A deformed shank nail shall have either a helical (screw) shank or an annular (ring) shank.

<sup>3</sup>Staples shall have minimum 7/16" crown widths.

<sup>4</sup>Spacing for 19/32" and 5/8" panel thicknesses up to 8" o.c. is permitted.

<sup>5</sup>Spacing for 19/32" and 5/8" panel thicknesses up to 4" o.c. is permitted.

**TABLE 45  
WALL SHEATHING, PANEL SIDING AND FLOOR UNDERLAYMENT ATTACHED TO WOOD MEMBERS**

Description of Attached Material	Attached Material Nominal Thickness (In Inches)	Spacing Specifications (In Inches) <sup>4</sup>		Fastener Specifications <sup>1,2</sup>	
		Edges	Intermediate	Minimum Leg Length (Inches)	Fastener Style <sup>3</sup>
Plywood Panel Siding	3/8	6	12	1 1/2	6d Galv. Casing Nail
					6d Galv. Siding Nail
					0.097 Galv. Finish Nail
	1/2	6	12	1 5/8	6d Galv. Casing Nail
					6d Galv. Siding Nail
					0.097 Galv. Finish Nail
	5/8	6	12	1 7/8	8d Galv. Casing Nail
					8d Galv. Siding Nail
					0.113 Galv. Finish Nail
Fiberboard Wall Sheathing	1/2	6	12	1 1/2	14 Gage Staple
		4	10		15 Gage Staple
		16 Gage Staple			
	25/32	5	10	1 3/4	14 Gage Staple
		4	8		15 Gage Staple
		16 Gage Staple			
Gypsum Wall Sheathing	1/2	5	10	1 1/2	14 Gage Staple
		4	8		15 Gage Staple
		16 Gage Staple			
Floor Underlayment	1/4	3	6-Grid	1 1/4	3d Ring Shank Nail
		2	5-Grid	7/8	18 Gage Staple 3/16" Crown Width
		2	4-Grid	1 1/4	0.080 Nail
	11/32	6	8-Grid	1 1/4	3d Ring Shank Nail
		4	6-Grid		16 Gage Staple
		0.080 Nail			
	15/32 - 19/32	6	8-Grid	1 1/4	3d Ring Shank Nail
		5	6-Grid		16 Gage Staple
		0.097" Nail			
	3/4	6	8-Grid	1 1/2	4d Ring Shank Nail
		5	6-Grid		16 Gage Staple

<sup>1</sup>Except as noted above, all staples shall have a minimum crown width of 7/16 inch.

<sup>2</sup>Steel wire fasteners exposed to the weather in service shall be zinc coated by a hot-dip, mechanical deposition or electro-deposition galvanizing process. Fasteners manufactured from aluminum 5056 or 6061 alloy wire or other nonferrous alloys do not require protective coatings. For construction to SBCCI SSTD 10, fasteners exposed directly to the weather or subject to salt corrosion in coastal areas, as determined by the building official, shall be stainless steel or hot dip galvanized after fabrication to 1 oz. per sq ft. For construction to UBC Appendix Section 2337, fasteners in exposed locations or in areas otherwise subject to corrosion shall have a corrosion resistance equal to or greater than a hot-dipped galvanized coating of 1.5 ounces of zinc per sq ft of surface area.

<sup>3</sup>0.080 nails and No. 18 gage staples are not listed in Table Numbers 1 through 3 and are for nonstructural use only as tabulated above.

<sup>4</sup>Fastening schedule only applies to buildings of conventional wood frame construction where wind or seismic analysis is not required by the applicable code. In areas where wind or seismic analysis is required, required fastening shall be determined by structural analysis. Following are conditions for which codes do not require structural analysis:  
 - *Uniform Building Code* - applications on buildings of conventional wood frame construction within the scope of applicability noted in Section 2320 of the *Uniform Building Code*.  
 - *International One and Two Family Dwelling Code* - See the IOTFDC for limitations of use associated with conventional wood frame construction.  
 - *International Building Code* - applications on buildings of conventional wood frame construction within the limitations noted in Section 2308 of the *International Building Code*.  
 - *International Residential Code* - Construction in regions where the basic wind speed from Figure R301.2(4) of the code equals or exceeds 110 mph (177.1 km/h) shall be designed in accordance with one of the documents referenced in the code. The code presents seismic requirements which must be met for buildings constructed in seismic design categories C, D1 and D2, with detached one- and two-family dwellings in category C exempt.  
 - *Standard Building Code* - applications design wind speeds do exceed 80 mph. See Section 2308.2 of the code for seismic limitations associated with conventional wall bracing.

**TABLE 46  
FASTENERS FOR ATTACHING ROOF AND WALL COVERING MATERIALS**

Spacing Specifications	Fastener Specifications <sup>1</sup>		
	Fastener Style	Minimum Crown Width, or Nail Head Diameter	Minimum Leg Length <sup>3</sup>
Asphalt Roof Shingles			
A Minimum of Four Fasteners Per Each 36"-40" Section of Shingle <sup>5</sup>	16 Gage Staples <sup>2</sup>	$\frac{15}{16}$ "	See Footnotes 3 & 4
	0.1055" Roof Nail	$\frac{3}{8}$ "	See Footnote 3
Wood Roof Shingles <sup>6, 7, 8</sup>			
A Minimum of Two Fasteners Per Shingle	16 Gage Staples <sup>9</sup>	$\frac{7}{16}$ "	1 $\frac{1}{4}$ "
	0.080" Nail	-	1 $\frac{1}{4}$ "
Wood Shakes <sup>6, 7, 8</sup>			
A Minimum of Two Fasteners Per Shingle	16 Gage Staples <sup>9</sup>	$\frac{7}{16}$ "	1 $\frac{3}{4}$ "
	0.0915" Nail	-	1 $\frac{3}{4}$ "

<sup>1</sup>Steel wire fasteners shall be zinc coated by a hot-dip, mechanical deposition or electro-deposition galvanizing process. Fasteners manufactured from aluminum 5056 or 6061 alloy wire or other nonferrous alloys exposed to the weather do not require protective coatings. For construction to SBCCI SSTD 10, fasteners exposed directly to the weather or subject to salt corrosion in coastal areas, as determined by the building official, shall be stainless steel or hot dip galvanized after fabrication to 1 oz. per sq ft. For construction to UBC Appendix Section 2337, fasteners in exposed locations or in areas otherwise subject to corrosion shall have a corrosion resistance equal to or greater than a hot-dipped galvanized coating of 1.5 ounces of zinc per sq ft of surface area.

<sup>2</sup>Use of staples in areas governed by the *International Building Code*, *BOCA National Building Code*, *Standard Building Code*, *International Residential Code* is outside the scope of this report.

<sup>3</sup>The staples or nail leg length shall be long enough to penetrate through the sheathing and extend beyond  $\frac{1}{8}$  inch or penetrate the sheathing  $\frac{3}{4}$  inch; all other provisions of this table will prevail.

<sup>4</sup>Asphalt shingles attached with staples are driven so that the staple crown bears tightly against the shingle but does not cut the shingle surface. The crown is parallel to the long dimension of the shingle course.

<sup>5</sup>Special fastening is required under the following conditions:

- The *International Building Code* requires special methods of fastening either (a) roof slope exceeds 20 units vertical in 12 units horizontal (20:12), or (b) roofs are located where the basic 3-second gust wind speed per Figure 1609 is 110 mph or greater.
- The *International Residential Code* requires special methods of fastening when either (a) roof slope exceeds 20 units vertical in 12 units horizontal (20:12), or (b) roofs are located where the basic 3-second gust wind speed per Figure R301.2(-4) is 110 mph or greater. Special fastening methods shall be tested in accordance with ASTM D 3161, modified to use a wind speed of 110 mph (177 km/h).
- The *BOCA/National Building Code* requires that asphalt strip shingles shall have a minimum of six fasteners per shingle where the structure is located in hurricane ocean-line areas along the Atlantic and Gulf of Mexico coastal areas and 100 miles inland where the basic wind speed is 80 miles per hour or greater, determined in accordance with the Basic Wind Speed map in the Code (Figure 1609.3).
- The *Standard Building Code* requires special methods of fastening when either (a) roof slope exceeds 20 units vertical in 12 units horizontal (20:12), or (b) roofs are located where the basic fastest-mile wind speed per SBC Figure 1606 is 90 mph or greater.
- SBCCI SSTD 10 requires that asphalt shingles be fastened with the type and number of fasteners recommended by the manufacturer. A minimum of 6 fasteners per shingle is required on roofs meeting any one of the following conditions: (a) The eave height is 20 feet or greater above grade, or (b) the Use Factor for the building is 1.15, or (c) the Basic Wind Speed is 100 mph or greater.
- the *Uniform Building Code* requires shingles to be attached per manufacturer's instructions in special wind regions
- the *International One and Two Family Dwelling Code* requires shingles to be attached per manufacturer's instructions in special wind regions. Additionally, a minimum of 6 nails per strip is required where roofs are located within 100 miles of hurricane ocean lines along the Atlantic and Gulf of Mexico coasts where the basic wind speed is 80 miles per hour or greater per Figure 301.2(4).

<sup>6</sup>Wood shingles and shakes attached with staples are driven so that the staple crown is parallel to the butt edge compressing the wood surface no more than the total thickness of the staple crown wire.

<sup>7</sup>Two fasteners shall be used to attach each shingle or shake. Fasteners for wood shingles and shakes shall be long enough to penetrate into the sheathing  $\frac{3}{4}$  inch or through the thickness of the sheathing, whichever is less.

<sup>8</sup>No. 18 gage staples with  $\frac{7}{16}$  inch crown may be used to attach shingles, provided the butt ends do not exceed  $\frac{3}{4}$  inch.

<sup>9</sup>When approved by the building official.

**TABLE 47  
STAPLES FOR ATTACHING WALL, CEILING AND SOFFIT COVERING MATERIALS TO  
WOOD RECEIVING MEMBERS ONLY<sup>1</sup>**

Minimum Leg Length (O.D.) (In Inches)	Description of Covering Materials <sup>2, 3, 5, 6, 7</sup>		Maximum Spacing (In Inches)		
			Vertical Surfaces	Horizontal Surfaces	
7/8	3/8 inch Gypsum Lath - Plain, Type X		8 <sup>8</sup>	8 <sup>8</sup>	
1	3/8 inch Gypsum Lath and Metal or Wire Stripping		-	5	
1 1/2	1/2 inch Gypsum Lath - Plain, Type X		8 <sup>8</sup>	8 <sup>8</sup>	
	1/2 inch Fiber Insulation Lath			6 <sup>4</sup>	
1 3/4	1 inch Fiber Insulation Lath		5	-	
	Laminating 3/8 inch Gypsum Lath and 3/8 inch Gypsum Wallboard				
7/8	3/8 inch Gypsum Lath Panels, Wallboard and Backer Board		7	7	
1 1/8	1/2-inch Gypsum Lath Panels, Wallboard and Backer Board				
1 1/4	5/8 inch Gypsum Wallboard and Backer Board				
1 3/4	Laminating 1/2-inch and 1/2-inch Type X Wallboard				
2	Laminating 3/8 inch and 3/8 inch Type X Wallboard				
7/8	Metallic Plaster Reinforcement	Welded or woven wire fabric	6	6	
		Expanded metal lath			Regular (non-furred and no ribs) Self-furred
					1/8-inch-high Rib Metal Lath
1 1/4		1/8-inch-high Rib Metal Lath	at ribs	at ribs	
1 3/4		1/8-inch-high Rib Metal Lath			

<sup>1</sup>Staples manufactured from No. 16 gage round, semi-round or flattened wire and, if used for attaching gypsum wallboard or gypsum lath, shall have a minimum 3/4 inch crown, measured outside the legs.

<sup>2</sup>Staples for attachment of exterior lath must be galvanized. When attached over fiberboard, rigid, expanded polystyrene or gypsum sheathing, the leg length shall be sufficient to provide a 1-inch penetration into the stud.

<sup>3</sup>All types of lath attached with staples are furred or non-furred, with or without paper backing. The welded or woven wire netting shall be pre-hung by conventional temporary nailing prior to staple installation.

<sup>4</sup>Supports spaced 24 inches o.c. Four attachments per 16-inch-wide lath per bearing. Five attachments per 24-inch-wide lath per bearing.

<sup>5</sup>Staples attaching metal or wire lath, stucco mesh and welded or woven wire netting shall have a minimum 7/16 inch crown, measured outside the legs.

<sup>6</sup>For attaching covering materials to redwood supporting members add minimum of 3/8-inch to fastener leg length.

<sup>7</sup>Steel wire fasteners exposed to the weather in service shall be zinc coated by a hot-dip, mechanical deposition or electro-deposition galvanizing process. Fasteners manufactured from aluminum 5056 or 6061 alloy wire or other nonferrous alloys exposed to the weather do not require protective coatings. For construction to SBCCI SSTD 10, fasteners exposed directly to the weather or subject to salt corrosion in coastal areas, as determined by the building official, shall be stainless steel or hot dip galvanized after fabrication to 1 oz. per sq ft. For construction to UBC Appendix Section 2337, fasteners in exposed locations or in areas otherwise subject to corrosion shall have a corrosion resistance equal to or greater than a hot-dipped galvanized coating of 1.5 ounces of zinc per sq ft of surface area.

<sup>8</sup>Three attachments per 16-inch-wide lath per bearing. Four attachments per 24 inch wide lath per bearing.

**TABLE 48  
STAPLES FOR ATTACHING WALL, CEILING AND SOFFIT COVERING MATERIALS  
TO METAL RECEIVING MEMBERS ONLY**

Wire Gage No.	Minimum Leg Length (O.D.) (In Inches)	Description of Covering Materials <sup>1</sup>	Staple <sup>2</sup> Spacing (Inches)	Type of Receiving Member
16	1 $\frac{1}{8}$	$\frac{3}{8}$ Inch Gypsum Lath	5	Approved Load and Nonloadbearing Nailable Studs "Only" Designed for Receiving Round Wire Staples or Conventional Nails
14			8	
16	1 $\frac{1}{4}$	$\frac{1}{2}$ Inch Gypsum Lath, Panels & Wallboard <sup>3</sup>	5	
14			8	
16	1 $\frac{3}{8}$	$\frac{1}{2}$ Inch Gypsum Lath, Panels & Wallboard	5	
14			8	
16	1 $\frac{1}{4}$	Metal Lath & Welded or Woven Wire Lath & Masonry Veneer Wire Mesh	6	
16	1 $\frac{3}{8}$	$\frac{3}{8}$ Inch High Rib Metal Lath	At Ribs	
16	1 $\frac{3}{4}$	$\frac{3}{4}$ Inch High Rib Metal Lath		

<sup>1</sup>Staples manufactured from round, semi-round or flat wire and shall have a minimum of  $\frac{7}{16}$  inch crown.

<sup>2</sup>Steel wire fasteners exposed to the weather in service shall be zinc coated by a hot-dip, mechanical deposition or electro-deposition galvanizing process. Fasteners manufactured from aluminum 5056 or 6061 alloy wire or other nonferrous alloys exposed to the weather do not require protective coatings. For construction to SBCCI SSTD 10, fasteners exposed directly to the weather or subject to salt corrosion in coastal areas, as determined by the building official, shall be stainless steel or hot dip galvanized after fabrication to 1 oz. per sq ft. For construction to UBC Appendix Section 2337, fasteners in exposed locations or in areas otherwise subject to corrosion shall have a corrosion resistance equal to or greater than a hot-dipped galvanized coating of 1.5 ounces of zinc per sq ft of surface area.

APPENDIX A

Reference

1997 National Design Specification® (NDS®), American Forest and Paper Association (AF&PA).

Development of Report Fastening Schedules

Fastening schedules in this report are based on fastening schedules found in model building codes. Fastening schedules in this report have connection strengths greater than or equal to the strength of the connection listed in the model building codes. Connection strength was analyzed based on lateral strength, withdrawal strength, or both, as appropriate.

Withdrawal Strength Values

The allowable normal (10 year) withdrawal loads per inch of penetration of a staple or smooth shank nail driven in side grain (perpendicular to the fiber) of seasoned wood, or unseasoned wood which will remain wet, is calculated by the following formula:

$$W = 1380 G^{5/2} D$$

where;

- W = the allowable load per lineal inch of penetration into the member holding the nail point.
- G = the specific gravity of the wood (See Table A)
- D = the diameter of the fastener shank in inches.

Threaded nails have design withdrawal strengths 10% greater than smooth shank nails of the same diameter.

Staple withdrawal strengths are calculated by doubling the calculated withdrawal strength of one leg.

Lateral Strength Calculations

Lateral design strength of connections is based on the yielding of connections as wood fibers are crushed and/or fastener shanks are bent. Figure A shows failure modes anticipated for nailed/stapled connections.

Figure A

Connection Yield Modes for Two-Member, Single Shear Connections

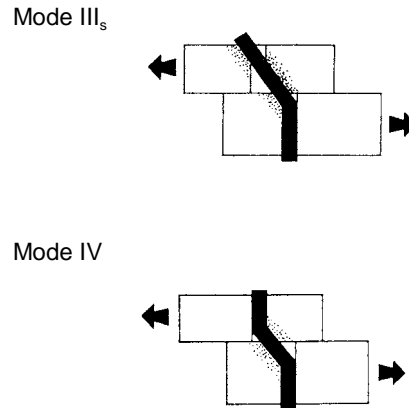
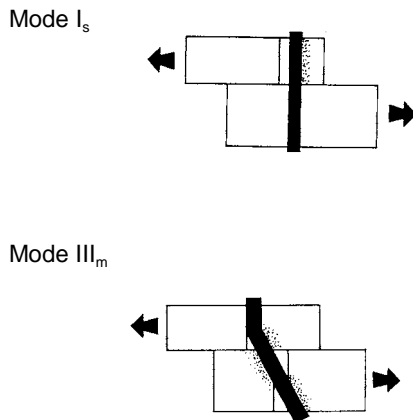

Below are formulas for the design loads associated with the various failure modes. The lowest load determines design load. The strength of nailed connections is affected by a nail property called "fastener bending yield strength." The strength of stapled connections is affected by a staple property called "bending moment."

Lateral Design Load Equations for Nailed Connections

These are the same formulas found in the 1997 National Design Specification® (NDS®) for nailed connections. Variables are defined following the equations for stapled connections.

for Mode I<sub>s</sub>

$$Z = \frac{D t_s F_{es}}{K_D}$$

for Mode III<sub>m</sub>

$$Z = \frac{k_1 D p F_{em}}{K_D(1 + 2R_e)}$$

for Mode III<sub>s</sub>

$$Z = \frac{k_2 D t_s F_{em}}{K_D(2 + R_e)}$$

for Mode IV

$$Z = \frac{D^2}{K_D} \sqrt{\frac{2F_{em}F_{yb}}{3(1+R_e)}}$$

**Lateral Design Load Equations for Stapled Connections**

Below are formulas for the design loads associated with the failure modes relevant to connections found in this report.

for Mode III<sub>m</sub>

$$Z = \frac{-t_s F_{es} D}{K_D (2 \frac{F_{es}}{F_{em}} + 1)} + \frac{F_{es} D}{K_D} \sqrt{\frac{t_s^2}{(2 \frac{F_{es}}{F_{em}} + 1)^2} + \frac{t_s^2}{2 \frac{F_{es}}{F_{em}} + 1} + \frac{4M}{F_{es} D (2 \frac{F_{es}}{F_{em}} + 1)}}$$

for Mode IV

$$Z = \frac{2F_{em} D}{K_D} \sqrt{\frac{M}{F_{em} D (1 + \frac{F_{em}}{F_{es}})}}$$

in which

$$k_1 = -1 + \sqrt{2(1 + R_e) + \frac{2F_{yb}(1 + 2R_e)D^2}{3F_{em}\rho^2}}$$

$$k_2 = -1 + \sqrt{\frac{2(1 + R_e)}{R_e} + \frac{2F_{yb}(2 + R_e)D^2}{3F_{em}t_s^2}}$$

$Z$  = nominal lateral design value

$R_e$  =  $F_{em} / F_{es}$

$\rho$  = penetration of nail or staple in main member (member holding point), inches

$t_s$  = thickness of side member, inches

$F_{em}$  = dowel bearing strength of main member (member holding point), psi (see Table A)

$F_{es}$  = dowel bearing strength of side member, psi (see Table A)

$F_{yb}$  = bending yield strength of nail or staple, psi

$M$  = staple bending moment, lbs.-in.

$D$  = nail diameter, inches, or wire diameter of wire from which staple is produced, inches. (When annularly threaded nails are used with threads at the shear plane,  $D$  = root diameter of threaded portion of nail.)

$K_D$  for nails:

$$\begin{aligned} &= 2.2 \text{ for } D \leq 0.17" \\ &= 10 D + 0.5 \text{ for } 0.17" < D < 0.25" \\ &= 3.0 \text{ for } D \geq 0.25" \end{aligned}$$

$K_D$  for staples:

$$= 2.2$$

Calculated loads are for normal (10 year) duration.

Adjustment factors for connections (such as load duration factor, wet service factor, etc.) must be applied to the computed nominal lateral design value to obtain allowable connection lateral design values. These formulae model the contribution of both staple legs.

**TABLE A**  
**WOOD SPECIES' SPECIFIC GRAVITY, DOWEL BEARING STRENGTH AND GROUP NUMBERS**

Species	Specific Gravity <sup>1</sup> , G	Dowel-Bearing Strength in Pounds per Square Inch (psi), F <sub>e</sub>	
		Nailed Connections	Stapled Connections
Aspen	0.39	2,950	3,840
Balsam Fir	0.36	2,550	3,430
Beech-birch-hickory	0.71	8,850	9,740
Coast Sitka Spruce	0.39	2,950	3,840
Douglas Fir-larch	0.50	4,650	5,540
Douglas Fir-south	0.46	4,000	4,880
Eastern Hemlock	0.41	3,200	4,120
Eastern Hemlock-tamarack	0.41	3,200	4,120
Eastern Hemlock-tamarack (north)	0.47	4,150	5,040
Eastern softwoods	0.36	2,550	3,430
Eastern Spruce	0.41	3,200	4,120
Eastern White Pine	0.36	2,550	3,430
Engelmann Spruce - Alpine Fir <sup>2</sup> (MSR 1650f and higher grades)	0.46	4,000	4,880
Engelmann Spruce - Alpine Fir <sup>2</sup> (MSR 1500f and lower grades)	0.38	2,800	3,700
Her-Fir	0.43	3,500	4,410
Mountain Hemlock	0.47	4,150	5,040
Northern Pine	0.42	3,350	4,260
Northern Species	0.35	2,400	3,310
Northern White Cedar	0.31	1,900	2,820
Ponderosa Pine	0.43	3,500	4,410
Red Oak	0.67	7,950	8,840
Red Pine	0.44	3,650	4,560
Sitka Spruce	0.43	3,500	4,410
Southern Pine	0.55	5,550	6,430
Spruce-Pine-Fir	0.42	3,350	4,260
Western Cedars	0.36	2,550	3,430
Western Cedars (North)	0.35	2,400	3,310
Western Hemlock	0.47	4,150	5,040
Western White Pine	0.40	3,100	3,980
White Oak	0.73	9,300	10,200
White Woods	0.36	2,550	3,430
Yellow Poplar	0.43	3,500	4,410

<sup>1</sup>Specific gravity based on weight and volume when oven dry.

<sup>2</sup>Applies only to Engelmann spruce-lodgepole pine machine stress-rated (MSR) structural lumber.

**TABLE B**  
**CONNECTION DEFLECTION VALUES FOR USE IN HORIZONTAL DIAPHRAGM AND SHEAR WALL DEFLECTION**  
**ANALYSIS<sup>1,4</sup>**  
**Nailed Connections**

Diameter (Inches)	Smooth Shank Nails							Deformed Shank Nails					
	0.092	0.099		0.113		0.120	0.131	0.148	0.098	0.113		0.120	0.131
Length (Inches)	2¼	2	2¼	2	2¾	3	2½	3	2¼	2	2¾	2½	2½
Load Per Fastener <sup>2</sup> (Pounds)	Connection Deflection <sup>3</sup> (Inches)												
60	0.003	0.006	0.002	0.002	0.001	0.001	0.002	0.001	0.007	0.003	0.001	0.007	0.006
80	0.008	0.012	0.005	0.004	0.003	0.002	0.003	0.002	0.010	0.006	0.003	0.012	0.007
100	0.016	0.025	0.009	0.009	0.006	0.003	0.005	0.003	0.020	0.010	0.006	0.019	0.008
120	0.033	0.046	0.016	0.015	0.009	0.006	0.007	0.005	0.037	0.014	0.009	0.028	0.009
140	0.060	0.079	0.027	0.030	0.014	0.009	0.011	0.007	0.061	0.024	0.013	0.039	0.009
160	0.090	0.137	0.046	0.054	0.023	0.014	0.017	0.010	0.089	0.040	0.020	0.053	0.010
180	0.117	0.286	0.075	0.087	0.037	0.021	0.025	0.015	0.121	0.063	0.030	0.074	0.014
200	0.151	—	0.100	0.116	0.057	0.032	0.040	0.021	0.193	0.089	0.043	0.094	0.019
220	0.186	—	0.132	0.156	0.086	0.049	0.064	0.030	0.354	0.100	0.061	0.116	0.024
240	0.228	—	0.163	0.200	0.100	0.078	0.097	0.044	0.548	0.130	0.082	0.148	0.028

<sup>1</sup>Decrease slip value by 17% for Structural I sheathing.

<sup>2</sup>Load per fastener is the diaphragm's maximum shear per foot divided by the number of fasteners per foot at interior panel edges.

<sup>3</sup>Values shall be doubled for unseasoned lumber.

<sup>4</sup>Values are for  $e_n$  in formulas found in UBC and IBC.

**TABLE C**  
**CONNECTION DEFLECTION VALUES FOR USE IN HORIZONTAL DIAPHRAGM AND SHEAR WALL DEFLECTION**  
**ANALYSIS<sup>1,4</sup>**  
**Stapled Connections**

Staple Gage	16		15		14	
Length (Inches)	1½	2	1¾	2½	2	2½
Load Per Fastener <sup>2</sup> (Pounds)	Connection Deflection <sup>3</sup> (Inches)					
60	0.008	0.003	0.008	0.005	0.005	0.003
80	0.016	0.006	0.016	0.010	0.011	0.006
100	0.032	0.008	0.028	0.015	0.019	0.009
120	0.055	0.010	0.048	0.025	0.032	0.014
140	0.087	0.024	0.077	0.040	0.050	0.021
160	0.135	0.037	0.118	0.060	0.077	0.031
180	0.205	0.052	0.173	0.088	0.113	0.044
200	—	0.092	0.244	0.127	0.157	0.060
220	—	0.198	0.299	0.178	0.219	0.080
240	—	—	0.346	0.220	0.287	0.097

<sup>1</sup>Decrease slip value by 17% for Structural I sheathing.

<sup>2</sup>Load per fastener is the diaphragm's maximum shear per foot divided by the number of fasteners per foot at interior panel edges.

<sup>3</sup>Values shall be doubled for unseasoned lumber.

<sup>4</sup>Values are for  $e_n$  in formulas found in UBC and IBC.

APPENDIX B

Recognized Fasteners by Listee

NAIL SIZE AND TYPE	DUBAI WIRE	HITACHI	MASTER FASTENERS	PREBENA AMERICA	PRIME SOURCE	STANLEY	TREE ISLAND	PASLODE/ DUOFAST	FALCON/ SPECIALTY	MAX USA	GERDAU AMERISTEEL	FASCO AMERICA
0.092	S	X, EG, HD				X			X			X, EG, HD
	R	X, EG, HD				X			X			X, EG, HD
	Sc	X, EG, HD				X			X			
0.095	S	X, EG, HD					NE, HD					
	R	X, EG, HD										
	Sc	X, EG, HD										
0.099	S	X, EG, HD				X	X, HD		X, H, SS, HD		X	X, EG, HD
	R	X, EG, HD				X	X, HD		X, SS, HD		X	X, EG, HD
	Sc	X, EG, HD				X	X, HD		X, HD		X	X, EG, HD
0.105	S											
	R					X						
	Sc											
0.113	S	X, EG, HD	X, EG		X	X, EG, HD	X, HD	X, HD	X, H, SS, HD	X	X	X, EG, HD
	R	X, EG, HD	X, EG		X	X, EG	X, HD	X, HD	X, SS, HD	X	X	X, EG, HD
	Sc	X, EG, HD	X, EG		X	X, HD	X, HD	X, HD	X, HD			X, EG, HD
0.120	S	X, EG, HD	X, EG		X	X, NE, EG, HD	X, NE, HD	X, HD	X, H, SS, HD	X		X, EG, HD
	R	X, EG, HD	X, EG		X	X, EG	X, HD	X, HD	X, SS, HD			X, EG, HD
	Sc	X, EG, HD	X, EG		X	X, HD	X, HD	X, HD	X, HD			X, EG, HD
0.131	S	X, EG, HD	X, EG		X	X, EG, HD	X, HD	X, HD	X, H, SS, HD	X	X	X, EG, HD
	R	X, EG, HD	X, EG		X	X, EG	X, HD	X, HD	X, SS, HD	X		X, EG, HD
	Sc	X, EG, HD	X, EG		X	X, HD	X, HD	X, HD	X, HD			X, EG, HD
0.135	S	X, EG, HD			X		X, HD					
	R	X, EG, HD			X		X, HD					
	Sc	X, EG, HD			X		X, HD					
0.148	S	X, EG, HD	X, EG		X	X	X, HD	X	X, H, SS, HD	X		X, EG, HD
	R	X, EG, HD	X, EG		X	X	X, HD	X	X, SS, HD			
	Sc	X, EG, HD	X, EG		X	X	X, HD	X	X, SS, HD			
0.162	S	X, EG, HD			X	X	X, HD		X, H, HD	X		
	R	X, EG, HD			X	X	X, HD					
	Sc	X, EG, HD			X	X	X, HD					
0.192	S						X, HD					
	R											
	Sc											
Staple Gage: 14 ga. 15 ga. 16 ga.				X X		X X X		X, EG EG X, EG				

## APPENDIX B

## Recognized Fasteners by Listee (Continued)

- S — Smooth shank nail  
 R — Ring shank nail  
 Sc — Screw shank nail  
 NE — Nonengineered nails. These nails have not been evaluated for conformance with the minimum bending yield strength stated in Section 3.3.2 of this report and Section S1 of ASTM F 1667. A typical example is roof nails used for the attachment of asphalt shingles where shank stiffness to resist lateral loads is not required.
- X, HD,  
 EG, SS  
 and H — Indicate that nails of this diameter and shank style, or staples of this gage, are recognized for this manufacturer for any nail shank length or staple leg length.
- X — The fasteners may be "bright" (nongalvanized), or galvanized to levels other than levels described by the HD or EG designations below.  
 HD — Hot-dipped galvanized, complying with ASTM A 153, Class D, having a minimum coating weight of 1.0 oz./sq.ft. Fastener cartons shall indicate "ASTM A 153" or the coating weight.  
 EG — Electrogalvanized, complying with ASTM A 641, Class 1, having a minimum coating weight shown below. Fastener cartons shall indicate "ASTM A 641, Class 1" or the coating weight.  
 SS — Stainless steel  
 H — Hardened

DIAMETER OF STAPLE LEG OR NAIL SHANK (inch)	CLASS I COATING (oz./ft <sup>2</sup> )
0.0625	0.15
0.080	0.25
0.092	0.28
0.148	0.35
0.192	0.50
0.207 and larger	0.53

Coating weights (mass) for diameters other than those shown are the coating weights (mass) for the next smaller diameter